



for your safety



EN 14594:
„LUNA” MH 211/8
ReS-4/M/ue, ReS-4M/OH/ue
ReS-4M/KL/ue, ReS-4M/OH/KL/ue,

Instruction of using :
COMPRESSED AIR HOSE APPARATUS

Gebrauchsanweisung :
DRUCKLUFT-SCHLAUCHGERÄT
mit Helm (Haube) zum Metallspritzen

Instrukcja użytkowania :
APARATU WĘZOWEGO SPRĘŻONEGO POWIETRZA
wyposażony w hełm do użycia w trakcie wykonywania
metalizacji natryskowej

The helmet's producer maintains an DIN EN ISO 9001:2015
quality management system certified by TÜV NORD.

CE 1437



INSTRUCTIONS FOR USE:

COMPRESSED AIR HOSE APPARATUS
EN 14594: 2018, EN 166: 2005; EN 170:2005

equipped with helmet (hood) to be using during metal spraying blasting

LUNA MH 211/8 the set includes:

1A. AIR HELMET:

“LUNA “ReS – 4M/ue; ReS – 4M/OH/ue*;

(*versions with built –in hearing protection);

2A. REGULATION SYSTEM ReS-URG/ue for the amount of inflowing air

Product possesses the **CE**1437 CERTIFICATE No WE/S/1570/2010

INSTRUCTIONS FOR USE:

COMPRESSED AIR HOSE APPARATUS
EN 14594: 2018, EN 166: 2005; EN 170:2005

equipped with helmet (hood) to be using during metal spraying blasting

LUNA MH 211/8 the set includes:

1B. AIR HELMET

„LUNA” ReS – 4M/KL; ReS – 4M/OH/KL*;

(*versions with built –in hearing protection)

2B. CLIMATE CONTROL TUBE ReS-ATR

Product possesses the **CE**1437 CERTIFICATE No WE/S/1570/2010

√ Helmet (apparatus) is designed to protect the respiratory system, head, face and eyes of the employee working with metal spraying.

This apparatus has been designed and made using the most modern technologies and passed rigorous quality control in accordance with ISO 9001 Quality Assurance System. Our goal is to ensure that each and every of our Clients is satisfied using RESIN products for many years.

RESIN HELMET FEED SYSTEM

Helmet (hood) should be fed by means of air with the pressure 7 bar. To obtain full scale of regulation of amount of breath air and temperature, it is necessary to feed by air with the pressure of minimum 6,5 bar and expenditure minimum 400 dm³/min. In any case we advise using of breath air treatment system i.e. Filter Set.

1. Compressed air with the compression to 7 bar obtained from the net of compressed air or the compressor.
2. System of air treatment for breathing aims: - Filter Set cleaning the breath air
3. One can use additionally other filters as a step of finishing cleaning.
4. Regulation System ReS-URG/ue. Appliance worn at the belt, enables the worker independent regulation of breath air amount given to helmet. **or**
5. Air conditioning set ReS-ATR used to regulation of amount and temperature of breath air feeding helmet. The set enables warming and cooling of air.

RESIN feed system increases the comfort and work security. In specially difficult conditions in which workers work with sand, it is invaluable equipment of work post.

IMPORTANT:

- ❑ Helmet does not ensure protection of breathing system in case of lack of coming of air to its interior.
- ❑ One should ensure the cleanness and identity/ repetition/ of air to breathing.
- ❑ Before work one should check compression of air source and intensity of air flow given to user in agreement with requirements described in the further part of instruction. And also in instruction of using FILTER SET which treat air to breathing aims.
- ❑ Before work one should read the instruction of user of REGULATION System ReS-UR/ue, check the state of filth of noise silencers of breath air in system ReS-URG/ue and in inlet pipe of air of helmet. The appearing filth might cause „stopping” of silencers and thus limit flow of air beneath of required level.
- ❑ Silencers should be changed not less frequently than once during 2 months of helmet work.
- ❑ Before work one should plug apparatus/ helmet/ to source of compressed air, put helmet on head and check working of indicator of breath air flow installed inside of helmet (over the window)
- ❑ In case of very intensive work in face part might appear great under- pressure in the phase of inspiration.
- ❑ In case of too much air humidity to breathe, during work in temperature below 4⁰ C, content of air humidity should be controlled to avoid freezing particular parts of helmet
- ❑ Do not use air enriched with oxygen.
- ❑ Use in temperature between - 10⁰ C to + 35⁰ C.
- ❑ Pipe leading breath air should be replaced after 2 years from production date. Ensure air temperature to breathe below 55⁰ C.
- ❑ In case of using Air Conditioning Set before work one should read instruction of its using.
- ❑ Attention ! - The internal side of the helmet window is covered with layer absorbing UV radiation. Avoid touching this layer with wet fingers (hands). Touching this layer can result in local discolouration of window glass.
- ❑ Before work worker should have specialist training as far as risk during vapour blasting treatment is concerned, which should be confirmed by proper documents.
- ❑ Producer advises using helmet individually for each worker, as an appliance of personal health protection.
- ❑ Level of noise reaching worker's ears connected with flow of breathing air through Adjustment System ReS-URG/ue in the amount of 150-165 dm³/min does not exceed the value defined in the EN 14594 standard, i.e. 80 dBA.
- ❑ Level of noise reaching worker's ears connected with flow of breathing air through Air Conditioning Set ReS-ATR in the amount of 150-165 dm³/min does exceed the value 80dBA. One should use noise reduction stopper into ears. We advice to use helmets in version O/H that have built insert with fixed hearing protection.
- ❑ Because of limitation of the seeing field the worker making the work in helmet should be in constant surveillance of other worker who could, if need be, give him help (according to advice of Central Institute of Work Protection *CIOP*).
- ❑ It is forbidden to join breathing air hoses with working media hoses.
- ❑ Information labels about product are located: on package, in user manual on cover and last page, on helmet near to socket of inlet of breath air and also on inner side of helmet. **CE** sign is located on metal label riveted to helmet.



Helmet (apparatus) MH 211/8 „LUNA” ReS-4M, ReS-4M/OH

The helmet is has the form of shell. In the face part it is equipped with a panoramic window in which there is a bent, 2 mm thick polycarbonate glass. The inner side of the window is covered with a golden-green coloured UV absorbing layer. The glass is mounted in a sealer attached to the edge of helmet viewfinder. The outer side of the glass is protected with a single protective foil. These foils can have the following colours: transparent, silver-brown, silver-grey, silver-blue. Colour of the protective foil is selected by the user himself depending on the specific working conditions and metal spraying method used. The viewfinder is closed with a hinged frame. The glass, foils, frame, sealer and protective apron are exchangeable. The apron is made of cotton fabric additionally reinforced in the chest area by the glass-fibre fabric covered with aluminium. The window protection foil is mounted on the clamps on the inner side of the upper part of the frame. It should be remembered to avoid its wearing through as this may result in unintentional damage to the window.



view of helmet



Sequence of assembly of „LUNA”

- A.** Polycarbonate panoramic glass [2] inserted in the profiled rubber sealer [1] attached to the edge of the viewfinder – protects worker's eyes and face.
- B.** Viewfinder glass protective foil [3] mounted on the inner side of the frame. In case of scratching or matting the protective foil should be replaced. Matting of the foil results in deterioration of visibility.
- D.** Hinged viewfinder frame [5], closed and locked by a snap clamp.
- E.** Clamps for mounting:
Foil package, single foil, net.

In case of damage, wear and tear of glass, foil, frame, hinges and clamp or sealer these elements should be replaced with new ones.

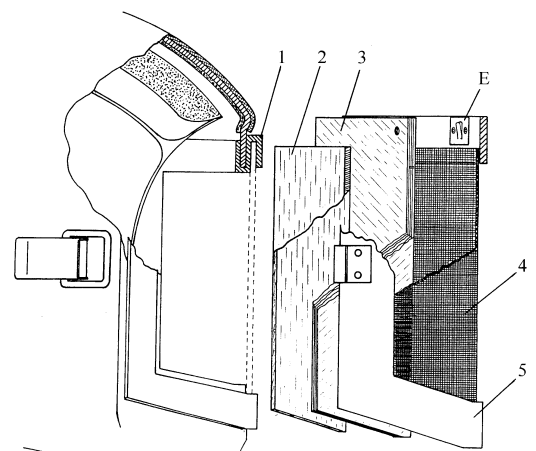

Fig.1

Product characteristics

The helmet (apparatus) protects face and torso of the employee working with metal spraying and also protects breathing system from created dust and other substances created metal spraying. In order for the worker to breathe freely in helmet and for the dust particles not to get inside, one requires feeding the helmet with clear compressed air (one should use set of filters to clean) Also it is required using the regulator of amount of given air. The amount of given air must ensure keeping inside the helmet overpressure in relation to environment, and free breathing. The amount of air delivered inside the helmets regulated by means of regulation system ReS-URG/ue, ensures delivering 165 dm³ /min. with the keeping of particular parameters of the net of compressed air. Regulation system is worn at the hip belt.

In case of using helmet with conditioner user can set himself temperature of breath air. ReS-ATR air conditioner set ensures delivering normative amount of breath air determined by producer (minimum 150-165 dm³/min). ReS-ATR conditioner is worn at the belt. It used physical effect related to air compression and decompression for temperature change of this air.

Inside the helmet (over the window) there is installed the indicator of air flow, which is at the same time warning appliance. The indicator helps the user to control the equipment before using and also during work - if minimal value of intensity of air flow was achieved. The indicator has movable element which appears in the seeing field of window in case of not achieving required intensity of flow (also in case of lack of flow). After ensuring required intensity of flow, movable element goes into the indicator vanishing from the seeing field of user.

WARNING ! The indicator works properly then the helmet is in the position as to work (i.e. as on the worker's head).
SEE FIG. 2 and 3 (view from the inside of helmet)



flow beneath 165 dm³/min indicator pulled off, flow above 165 dm³/min, indicator inside

The helmet has inside insert with changeable cushions of upholstery fixed by catchers that advantage is fitting the head shape. Way of fixing of insert allows for quick dismantling of upholstery cushions in order to change or wash and also to clean the inside of helmet.

Figure No 4 depicts insert with upholstery with fixing and regulation elements.



- A - insert shell with upholstery
- B - belt of holding the insert
- C - belt of regulation of insert pressure to head
- D - catch of pressure belt
- E - screws fixing back part of insert

- holes 1-5 in belt **B** enable holding the insert in helmet shell at the height required by the user

- holes 1-5 in belt **C** depending on fixing on the „nail” enable increasing or decreasing strength of pressure of insert to head.

Insert in helmet shell is fixed by means of screws **E** and seals in back part and by means of screws by belt **B** to sides of helmet shell.

Fig.4

To ensure hygienic conditions of user, to helmet is added cotton cap. It should be put on head before work. From time to time it should be washed in water with the delicate detergent.

Version of helmet with built in protection of hearing ReS-4M/OH

Helmet in version O/H has built insert with fixed hearing protection. Insert construction enables easy putting the helmet on and off the head. Used system of insert pressure and way of fixing of hearing protection allows for individual fitting the helmet to head. Way of fixing of insert allows for it quick taking off (e.g. to clean the helmet inside). Fig. No 5 depicts the upholstery insert with its fixing and regulation elements.

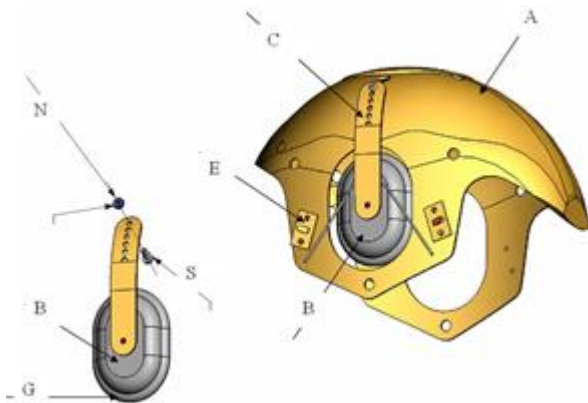

- A. shell of insert with
- B. hearing protection
- C. belt of holding the insert
- D. belt of regulation of insert
- E. catch of pressure belt
- F. screws fixing the back part of insert

holes 1-5 in belt C allow for holding the insert in helmet shell at the height required by the user

holes 1-5 in belt D depending on holding on the „nail” allow for increasing or decreasing strength of pressure of insert to head.

Fig. No 5

Earaches of hearing protection are fixed in the insert on independent rubber elements. That allows for uniform distribution of pressure strength of earcaps cushions around ears and does not require from the user additional activities during putting on or off of the helmet / lack of headband/. Insert in helmet shell is fixed by means of screws F in back part and by means of screws through belts C to sides of helmet shell.

There is an exchangeable apron mounted to the edge of the helmet using a velcro tape. The apron is made of two fabrics: dust-proof and aluminium covered and additionally protected against wear-through by the 6 cm wide rubber band in the place it is connected to the helmet.

In order to change (used out) apron or to take it off to wash one should:

- take off the rubber tape protecting border of changeable apron
- from the back of the helmet (under the inlet delivering the air) untie the pulling off line
- beginning from the back of helmet take off the apron.

In order to put on the apron once again one should:

- In case of damage of woven line, pull in the tunnel the new one/ by means of safety-pin/
- put the apron from the front part of helmet putting uniformly, pull the line in tunnel of apron and tie in a knot
- put rubber tape at the back of helmet (under the inlet with hose) and pull it with hands in the direction of front part of helmet. It is advised to do this in two persons.
- exact putting of tape on the border of helmet (3-5 mm beneath the border) protects the apron from too much destroying in the place of connection with the helmet.

Not pulling together of tapes of helmet apron and thus loose hanging down of its parts, does not guarantee the safety and may cause its quick damaging.

Changeable apron protects neck and torso of worker. The shell of the helmet is made of resin-glass fibre composite. Inside part of helmet shell in version O/H is glued by layer of foam with the thickness of 3-4mm. The foam is the layer sound absorbing and is thermic isolation very important in using Air Conditioning Set [ReS-ATR] that warms or cools delivered breath air. User's head is in the inside insert, with „cushions” of polyurethane resins foam. This increases the comfort of work. The cushions are fixed to inside insert of helmet by catchers. They should be from time to time cleaned by washing in water with the delicate detergent. After drying, the cushions are fixed on the proper place. Delivery of air to helmet is done through the elastic air hose that ensures delivery of air in all necessary movements of head during using of helmet.

* The helmet is equipped in noise silencer of the delivered breath air. The silencer is at the back of the helmet. It is element of inlet of air.

ATTENTION!

In case of using the air conditioning set ReS-ATR (because of occurring drags of air flow on the silencer and at the same time lowering of air temperature delivered to helmet) it might be necessary getting rid of silencer. Then one must use completed inserts to ears together with helmet or use other ones that are at the market, having the certificate **CE**.

We disassemble the silencer from the socket of inlet of breath air that is at the back part of the helmet according the below procedure:

- A. By means of pliers or pressure key take the inlet between Norma tape and protection of socket (point no 6) and screw out of the socket.
- B. Take out of the socket the silencer.
- C. Put precisely seal (that is added to spare parts) inside the socket.
- D. Screw the inlet into the socket. Screw home until felt refusal.

Description of figure no 6:

1. Noise silencer **3M0012**
2. Inlet socket
3. Inlet **3M0799**
4. Rubber protection of inlet **3M0071**
5. Norm's pressure tape **3M0241**
6. At this place take the inlet during screwing out

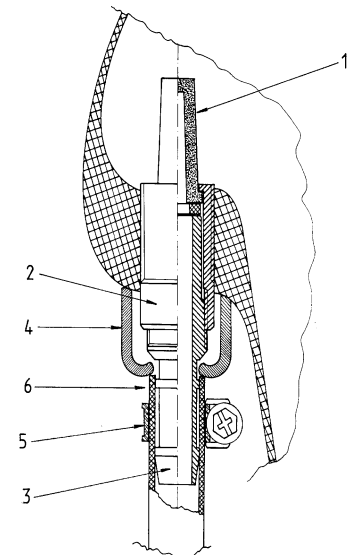

Technical and operating parameters

The helmet protects the head and body of the worker against chipping of the material used for metal spraying, face and respiratory system against dust and other harmful substances formed during metal spraying as well as eyes against UV radiation. Protective action of the helmet is ensured by a leak-proof viewfinder and an overpressure of clean air supplied into the helmet, which make it impossible for dirty air to penetrate under the helmet. The viewfinder glass is covered with a UV absorbing filter layer [filter designation 3 – 3]. The helmet is isolating the worker from the atmosphere of air unsuitable for breathing. Ensuring volumetrically proper flow of air is the condition for proper protection of respiratory system by the helmet. Using the ReS-URG/ue Adjustment System the user can himself adjust the amount of inflowing air. With pressure specified in point 3 and fully closed valve knob, the minimum required amount of air flows through the URG/ue. The air flow indicator positioned within the view range of the worker informs him of supplying the proper amount of air. This flow ought to be increased with effort and as needed.

1. Technical-using parameters of helmet

- mass of complete helmet	2,55 kg	- mass of helmet in version O/H	2,60 kg
- mass of changeable apron	0,75 kg	- mass of air inlet	0,17 kg

2. Minimum requirements of air flow intensity to helmet (with the regulation upwards) **165 dm³/min**

3. The source of feeding: the net of compressed of air treatment for breathing aims with the pressure of 7 bar with the possibility of pressure regulation/ pressure reducer/ to value 6,5 bar

- scope of regulation of air amount by the regulation system ReS-URG/ue: from 165 (±10) dm³/min to 280 (±10) dm³/ min.

- by pressure of delivery: *minimum 6,5 bar (for 10 m of the hose leading the air) / minimum 7 bar (for 50 m of the hose leading the air)*

Attention! Value of pressure on the reducers set after fixing of pipes of Regulation System ReS-URG/ue (opening of air flow).

4. Mass of regulation system **0,35 kg**

ATTENTION ! In case of deterioration of visibility through the **ReS-4M**,... viewfinder you need to :

Open the viewfinder frame, remove the protective foil from the clamps on the inner part of the frame, mount the new protective foil. After attaching the foil close the frame. In order to replace the panoramic glass you need to open the frame, remove the glass from the profiled sealer and insert the new glass. Then lock the viewfinder with the snap clamp. It is important that during replacement of the glass you don't touch the inner side of the glass with wet fingers (hands). The inner side of the panoramic glass is covered with a UV filter layer, absorbing ultraviolet radiation. Touching the filter may result in local discoloration of the glass.

ATTENTION !!

Because of occurring of excessive noise at the work post one advises using helmet in version O/H equipped in hearing protection.

Because of the level of noise at the place of leading the work/ that as a rule exceeds the norms/ for the additional increasing of protection parameters, each helmet is equipped in protective inserts to ears that are used to additional hearing protection type 3M 1100 whose use is allowed at works done in helmets according to certificate **CC**. Thus is created double protective barrier from noise coming to the workers ears, i.e. helmet shell together with upholstered insert enclosing the user's head (as a first barrier) + above mentioned ear inserts. Using mentioned inserts/ and others with similar parameters/ one gets the required level of protection. With the noise of low frequencies acoustic effectiveness of noise silencing of protective inserts Sf is 24 dB, and with the noise of high frequencies effectiveness Sf is 31 dB. In the whole scope of sound (noise) frequencies silencing Zr is 31 dB. That means that using above mentioned ear inserts we lower the level of noise coming to the inside of ear below 85 dB(A). Shortly speaking, from the level of noise occurring inside the helmet one should subtract value of silencing Zr dB(A) given in the instruction for using of ear inserts

Method of use

Before using one should fit the helmet and tapes of changeable apron. Fix the pipe delivering the breath air to the end of instant connection URG/ue by means of pressure tape. Put the breathing pipe of helmet on the end part going out of the system, screw the pressure tape. Fix the instant connection to regulation system. At the moment of fixing the instant connection the opening takes place. Set on the reducer of filters set- from which we deliver the breathing air treated - the pressure should be at the level described above. Put the helmet on head, and changeable apron and clasp the apron belt by means of plastic clasp.

Regulate by the handwheel the amount of air delivered to helmet. By pressure of compressed air described above, by the regulation system flows required amount of air (165 dm³/min +/- 10 dm³/min). After achieving the required flow, movable element goes into the frame of indicator, vanishing from seeing field of the window. Lack of this element in the seeing filed informs the user about delivering inside the helmet the required amount of breath air. Every time the appearing of movable element of the indicator in the seeing field means lack of required amount of air delivered to helmet. Then one should increase the flow by screwing out the handwheel of the Regulation System ReS-URG/ue. If this does not increase the flow of air, one should stop the work!!! and check the source of compressed air, filters, hoses and silencers. In case of damage, stopping the source of compressed air, filters, hoses or silencers one should before working again remove the damages, eventually give new ones. With need and increase of effort of work increase amount of flowing air. In case of break in breath air flow leave the working post.



Before work one should check:

- Before work plug the apparatus (helmet) to source of compressed air, put the helmet on the head and check working of indicator of breath air flow installed inside the helmet (over the window).
 - Correctness of working of signalization of flow of breath air:
 1. Lowering the air flow below required value: *Putting out the movable element of indicator in the seeing field of window.*
 2. Achieving the required value of flow: *Lack of movable element of indicator in the seeing field of the window.*
 3. Lack of delivering of the breath air- *Movable element of the indicator in the seeing field of the window.*
- State of dirtying of the noise silencers of breath air in the regulation system and inlet of air. occurring dirt might cause „stopping” of silencer and thus limit the air flow below required level. Silencers should be changed every time after stating lowering the level of flowing air to inside of helmet but not more rarely than once every two months of helmet work.
- correctness of setting the glass and seals of the window
- visibility through the viewfinder set: panoramic glass with UV filter and protective foils; in case of matting or scratching these elements should be replaced with the new ones
- fitting the insert to head - in case of necessity change the level of deflecting the pressure belt of insert
- level of pressure of ear protection of hearing (regulation as above) **concerns the version O/H**
- level of dirtying of upholstery cushions fitting the head: in case of dirtying the cushions of upholstery wash, dry and put once again at the same place
- technical state of inlet delivering the breath air
- technical state, possibility of regulation of regulation system
- state of frames and elements of closing the frame- in case of too much using of frame i.e. becoming of borders thin, cracking of surface- change bad elements
- condition of exchangeable apron, especially in the vicinity of joint with helmet edge and front part reinforced with aluminium coated fabric
- state of the helmet shell, especially at the front part and under the window at the border
- state of filters- certainty of connection and reliability of work of the source of feeding the compressed air installation
- value of pressure set on the pressure regulator that is placed at the installation of compressed treated air

Method for cleaning, conservation and storing

After the finished work the helmet should be cleaned, inside of helmet should be cleaned with wet material then disinfecting liquid „Nano Silver” and dried. Check technical state of inlet delivering the air. Regulation System should be blown by compressed air, check tightness of connections and presence of dirt in the transparent system casing.. In case of stating dirt, control the technical state of source of compressed air. Only wholly capable equipment- helmet, flow indicator and regulation system- can be used. In case of using the filters set, remove oil-water condensate from the particular steps of cleaning sets.

To do this one should every day after finished work remove drain plug lying at the lower part of casing of given cleaning step, and remove the feeding of compressed air.

Then automatic release of condensate takes place by automatic valve that is there. The remaining information concerning the use of filters set are place in the instructions of sets use.

Viewfinder glass can be washed with water with mild detergents. **NEVER** use any organic solvents as this causes matting of the glass. In case of excessive wear and tear of specific parts, the user should restore full protective capabilities of the helmet by replacing such elements, ordering them from the manufacturer.

The helmet should be stored in temperature from +5° C to +30° C and relative humidity of air to 85%. One should ensure conditions of transport that will not cause damage of helmet and especially window glasses. Do not throw products. Protect from atmospheric rain.

Safety parameters of the helmet completed with the ReS-ATR air conditioner



Description of the ReS-ATR air conditioner

The ReS-ATR air conditioner is designed for adjusting the temperature of breathing air supplied to the helmets and air hoods. The ReS-ATR air conditioner heats up or cools down the breathing air supplied to the equipment protecting the respiratory system supplied from the compressed air system, ensuring the supply of the proper amount of breathing air necessary for working safely when wearing the helmet. The user is kept informed by the breathing airflow indicator [See description on page 3]. After reaching the required minimum flow, a moveable element is inserted into the indicator casing and disappears from the visor's field of view. If this element ["the wing"] is not seen in the field of view, it confirms to the user that the right amount of breathing air was supplied inside the helmet. Each time when the indicator's "wing" appears in the field of view, it indicates that the right amount of breathing air was not supplied inside the helmet. In such case one should leave the workstation and check the source of compressed air, filters and hoses.

Operating principle: Compressed air flows through the inlet stub into the working chamber, where the temperature of the inlet air is changed. Part of the air is heated up, and some portion cooled down. Both air streams – hot and cold – are properly directed with the use of "the steering gear". If we take only hot air, all the cold air is exhausted from the air conditioner. Hot air is directed to the outlet stub in the air conditioner. If we take only cold air, all the hot air is exhausted from the air conditioner. Cold air is directed to the outlet stub in the air conditioner. The steering gear allows the air streams (hot and cold) to be mixed. The user is therefore able to independently adjust the breathing air temperature. It should be remembered that compressed air supplied to the ATR air conditioner should be free from water (condensing when compressed). Otherwise – in low ambient temperature – water present in the air may freeze on the elements of the equipment and hinder its proper operation.

Safety parameters of the MH 211/8 ReS-4M (ReS-4M/OH) helmet

The helmet protects the employee's head and trunk from chips of material used in the metallization process. It also protects the face and respiratory system from dust and other hazardous substances produced during the spray metallization process, as well as protecting the eyes from UV radiation. The leak-proof visor and clean air supplied inside the helmet, which produces overpressure, ensures protection by preventing polluted air from getting inside the helmet. The visor glazing is equipped with a filter, which absorbs UV radiation [filter marking 3 – 3 according to EN-170 standard clause 4]. The helmet isolates the user from atmospheres containing air unsuitable for breathing. Maintaining the appropriate intensity of airflow volume ensures the proper operation of the helmet as protection for the respiratory system. The user adjusts the breathing air temperature himself using the ReS-ATR air conditioner. The minimum required amount of air flows through the air conditioner at the pressure specified below.

An airflow indicator placed in the employee's field of view informs him about the supply of the proper amount of air. The flow should be increased according to the intensity of effort and requirements.

- Total weight of the helmet (not exceeding)	2.35 kg
- Weight of the helmet in O/H version [with hearing protection]	2.40 kg
- In this detachable apron and hose	0.92 kg
- Air hose diameter	10 mm

**Sequence of actions when heating the air with the use of the ReS-ATR
air conditioner:**

Supply treated breathing air through the hose of 10 mm diameter to the quick joint (1). Connect the joint to the inlet end (2) the air conditioner.

1. Connect the air treated for breathing purposes at a pressure of 5,7 [$\pm 0,1$] bar and delivery rate min. 400 dm³/min to the air conditioner.
2. Move the “steering gear” lever (3) anticlockwise adjusting the air temperature until resistance is felt [as in the directions on the casing]. Then maximum efficiency for heating up the air flowing out of the ReS-ATR air conditioner is achieved
3. Place a thermometer on the outlet stub (4) of the air conditioner and adjust the required air temperature using the “steering gear” lever (3). Check the temperature reached at various positions of the steering gear lever.
4. The proper amount of breathing air [150-165 dm³/min] required to ensure safe working conditions is supplied to the helmet at a pressure of 5,7 [$\pm 0,1$] bar of the compressed air supplied to the air conditioner, when the maximum air heating up level {the steering gear lever moved max. anticlockwise} is applied.
5. **CAUTION!** When supplying air to the air conditioner at a lower pressure, the proper amount of breathing air inflowing to the helmet (as required by the producer) will not be ensured, despite the required air temperature being reached.
6. After temperature and flow are adjusted, the helmet hose should be connected to the outlet in the air conditioner. The hose connected to the helmet should be as short as possible, in order to eliminate temperature changes during airflow. However, the hose should not restraint head movements.
7. The range of temperature adjustment at the outlet of the air conditioner at the temperature of supplied air from +10°C to +20°C is: from +5°C [± 3 °C] to + 50°C [± 4 °C]
8. **CAUTION.** The air conditioner casing may reach a temperature below zero. A layer of hoarfrost on the casing is a normal condition.
9. **CAUTION.** Air at a low temperature [approx. -10°C] is exhausted from the opening on the steering gear. Be careful!

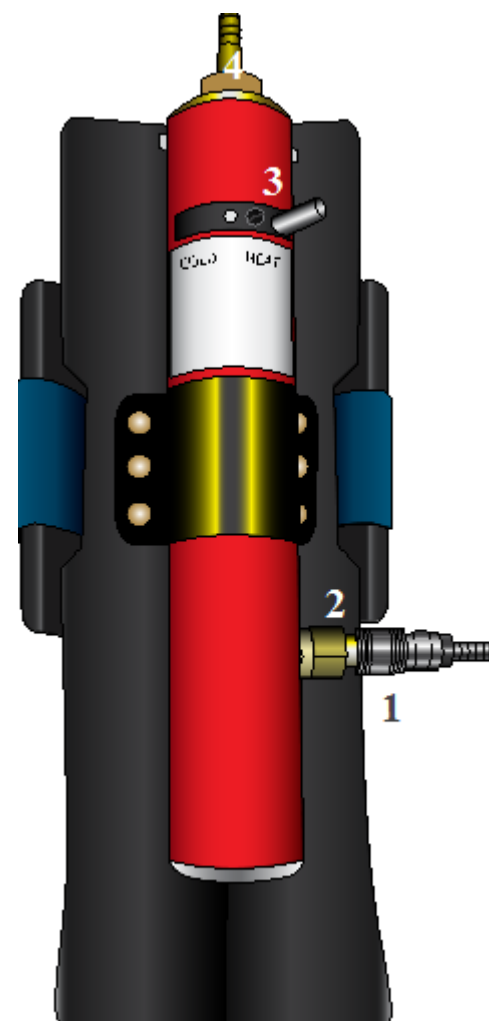

Sequence of actions when cooling the air with the use of the ReS-ATR air conditioner:

Supply the treated breathing air through the 10 mm diameter hose to the quick joint (1). Connect the joint to the inlet end (2) the air conditioner.

1. Connect the air treated for breathing purposes at a pressure of 4,5-5,7 [+/-0,1] bar and delivery rate min. 400 dm³/min to the air conditioner.
2. Move the “steering gear” lever (3) clockwise adjusting the air temperature until resistance is felt [as in the directions on the casing]. Then the maximum efficiency for cooling the air flowing out of the ReS-ATR air conditioner is achieved
3. Place a thermometer on the outlet stub (4) of the air conditioner and adjust the required air temperature using the “steering gear” lever (3). Check the temperature reached at various positions of the steering gear lever.
4. The proper amount of breathing air [170-190 dm³/min] required to ensure safe working conditions is supplied to the helmet at a pressure of 4,5- 5,7 [+/-0,1] bar of the compressed air supplied to the air conditioner, when the maximum air cooling down level {the steering gear lever moved max. anticlockwise} is applied.
5. **CAUTION!** When supplying air to the air conditioner at a lower pressure, the proper amount of breathing air inflowing to the helmet (as required by the producer) will not be ensured, despite the required air temperature being reached.
6. After temperature and flow are adjusted, the helmet hose should be connected to the outlet in the air conditioner. The hose connected to the helmet should be as short as possible, in order to eliminate temperature changes during airflow. However, the hose should not restraint head movements.
7. The range of temperature adjustment at the outlet of the air conditioner at the temperature of supplied air from +10°C to +20°C is: from +5°C[+/-3 °C] to + 50°C [+/-4 °C]
8. **CAUTION.** The air conditioner casing may reach a temperature below zero. A layer of hoarfrost on the casing is a normal condition.
9. **CAUTION.** Air at a high temperature [approx. 30°C] is exhausted from the opening on the steering gear. Be careful!

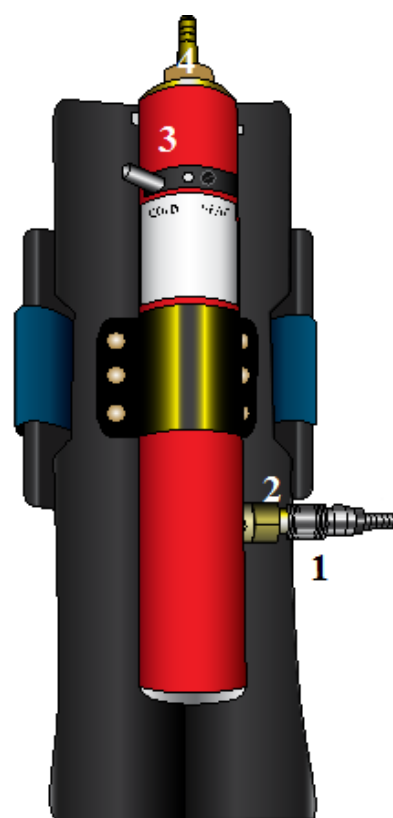
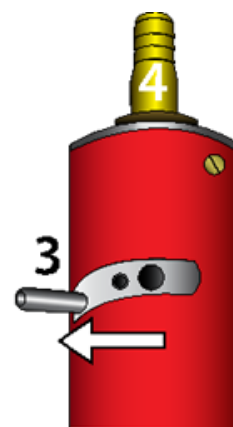

CAUTION!

When using the EndeCO set of filters (which treat the air for breathing purposes), due to resistance in the airflow on the filtering elements, the air pressure should be adjusted at the reducer of this set in order to ensure a minimum rate of air delivery at the air conditioner outlet (“hot” or “cold”), according to the specification below [for one work station]:

- for the length of the hose from the set of filters to ReS-ATR = 10÷25 m - not less than 4,5- 5,7 bar
- for the length of the hose from the set of filters to ReS-ATR = 26÷50 m - not less than 4,5-6,0 bar

CAUTION ! Adjust the pressure value at the reducer after connecting the hoses and the air conditioner (opening the airflow).

Technical parameters of the air conditioner:

- Supply pressure: 4,5 -5,7 [+/-0,1] bar
- Maximum supply pressure: 7 bar
- Amount of air at the outlet at maximum heating up rate (for supply pressure 4,5- 5,7 [+/-0,1] bar) : 150-165 dm³/min
- Amount of air at the outlet at maximum cooling down rate (for supply pressure 4,5- 5,7 [+/-0,1] bar) : 170-190 dm³/min
- Weight of the ReS-ATR air conditioner: 0,75kg
- Range of temperature adjustment at the outlet from the ReS-ATR air conditioner [at the pressure of 4,5- 5,7 [+/-0,1] bar and ambient temp. 18°C]: from +5°C[+/-3 °C] to + 50°C [+/-4 °C]
- Demand for air supplied to the air conditioner (for supply pressure 4,5-5,7 [+/-0,1] bar): 400 dm³/min [+/-25 dm³/min]

DECLARATION OF CONFORMITY

Przedsiębiorstwo RESIN PL 32-052 Radziszów Jurczyce 111

Declares with full responsibility, that the below described product. Compressed Air Hose Apparatus for the protection of the respiratory system, the head and eyes of the user employed in the abrasive blasting workplace EN 14594, EN 166; EN 170;

MH 211/8 ReS-4M „LUNA”consisting of :

- A. Breathing Helmet and ReS-URG/ue Adjustment System Type (variety) „LUNA”:
ReS-4M/ue; ReS-4M/OH/ue
- B. Breathing Helmet and Climate Control Tube ReS-ATR Type (variety) „LUNA”:
ReS-4M/KL; ReS-4M/OH/KL referred to in this declaration:

- Is entitled to mark the product with **CE** 1437 sign.
- Conforms to the following regulations, standards and standard documents:
- with the provisions of Regulation (EU) 2016/425 of European Parliament and of the Council of 9 March 2016;
- 1. EN 14594: 2018 “Respiratory protective devices – Continuous flow air line breathing apparatus – Requirements, testing, marking”
- 2. EN 166: 2005 “Personal eyes protection. Requirements”.
- 3. EN 170: 2005 “Personal eyes protection. Filters protecting against ultraviolet ...”.
- 4. Manufacturer’s Technical Documentation for Compressed Air Pipe Apparatus equipped with a helmet for use during metal spraying DT-nr 18 ReS-4.1.M. ATR UE
- Identical to the personal protection system for which the WE/S/1570/2010 certificate of conformity was issued by the Polish Central Institute for Labour Protection, notified body number: 1437
- Subject to the procedure specified in Article 19(C) (modelu C2) of Regulation (EU) 2016/425 of the European Parliament and of the Council, under supervision of the notified unit: **CIOP** 1437

This EU Declaration of Conformity is issued under the sole responsibility of the manufacturer.

Declaration of conformity available at: www.resinbhp.com.pl

Risk related to the expected use conditions

BREATHING APPARATUS EQUIPPED WITH A HELMET
DESIGNED FOR USE IN ABRASIVE BLASTING EN 14594:2018

Assessment of risk related to the use of the apparatus (helmet)			
Risk description	Methods and measures taken to avoid the incident	Reference in the standard	Risk assessment: Very high – VH High – H Medium – M Small – S Negligible – N
Allergies, skin irritation, carcinogenicity or other harmful effects of clothing materials.	Materials that come into direct contact with the user’s skin or that may affect the quality of the breathing air do not cause skin irritation or any other adverse effects to health.	EN 14594, section 6.3	S
Impact of materials on breathing air quality.	Materials that may affect the quality of the breathing air do not cause skin irritation or any other adverse effects to health.	EN 14594, section 6.3	S
Sharp or rough edges of clothing cause irritation.	The apparatus (helmet) does not have any sharp or rough edges that cause irritation. If a rough, sharp patch is found on the helmet due to wear, the user should leave the workstation and replace the helmet with a new helmet that offers full protective performance for abrasive blasting (relevant requirements are included in the user manual for the product).	EN 14594, section 6.3	N

Noise reaching the user's ears	Suitable measures have been used to ensure that the level of noise caused by the supply of breathing air that reaches the user's ear is lower than 80 dB(A). Ear plugs are provided with each apparatus (helmet) for additional hearing protection. The risk increases if the ear plugs are not used. The apparatus in the OH version has integrated internal noise protection earmuffs.	EN 14594, section 6.16	M
The shell of the apparatus (helmet) or apron is worn, cracked, torn or punctured.	The strength of the apparatus (helmet) has been tested in terms of wear resistance, seam strength and material breaking strength. The apparatus meets the requirements of the standard. If any of the above-mentioned types of damage are found on the helmet or on the protective apron, the apparatus should be discarded and replaced with a new apparatus that offers full protective performance for abrasive blasting (relevant requirements are included in the user manual for the product).	EN 14594, section 6.22 section 6.16 section 6.17	H
Eye or face injury if the visor glass breaks.	The visor glass meets the impact resistance requirements in accordance with section 7.2.2 of PN-EN 166.	EN 14594, section 6.16	M
No supply of breathing air to the helmet.	Connections of components related to air supply meet the requirements of the standard. Load-bearing components (belt) meet the requirements of the standard. Inside the apparatus (helmet), there is a breathing air flow indicator to warn the user when there is no air supply. The lines that supply breathing air and the breathing hose meet the requirements of the standard. The valve supplying the breathing air and the air conditioning unit meet the requirements of the standard. Since the apparatus (as self-contained breathing apparatus) is designed for use in environments with air unsuitable for breathing and not in environments with toxic fumes and gases, the user can leave the workstation after finding that the air supply has stopped.	EN 14594, section 6.6 section 6.7 section 6.11 section 6.21 sections 6.12 and 6.13 section 6.14 section 6.20	M
Carbon dioxide content in breathing air.	At the rated breathing air flow rate into the helmet, the CO ₂ content is lower than 1.0% (by volume). If there is no air supply, the user should leave the workstation.	EN 14594, section 6.19	H
Working in a damaged helmet – leaks	At the rated breathing air flow rate into the helmet, the helmet should provide protective performance despite the leaks. The product meets the requirements of the standard concerning internal leaks. If there is no air supply, the user should leave the workstation.	EN 14594, section 6.17	M
Dust gets inside the apparatus.	At the rated breathing air flow rate into the helmet, the helmet should provide protective performance despite the leaks. If such symptoms appear, this means that an insufficient amount of breathing air is supplied into the helmet or that visor closing components are worn out.	EN 14594, section 6.16	S
Work in low and high temperatures.	Provision in the manual indicating that the apparatus should be used in the ambient temperature range from minus 10°C to plus 35°C. An air conditioning unit can be used to improve user comfort.	User manual	N
Supply of breathing air with incorrect supply pressure.	Information about breathing air supply pressure included in the user manual. The manufacturer does not have any control over the user's behaviour.	User manual	H
Supply of air unsuitable for breathing.	Information about breathing air supply parameters included in the user manual. The manufacturer does not have any control over the user's behaviour.	User manual	H

Using oxygen-enriched air.	Information about oxygen-enriched air included in the user manual. Oxygen-enriched air should not be supplied for breathing under any circumstances. Health and safety hazard. The manufacturer does not have any control over the user's behaviour.	User manual	VH
Accident at work due to the limited field of view of the helmet user.	Provision in the manual indicating that the employee working in the apparatus (helmet) should be constantly observed by another employee to provide assistance when necessary. The manufacturer does not have any control over the user's behaviour.	User manual	H
Work in a faulty apparatus (helmet).	Provision in the user manual requiring a periodic inspection of the apparatus by the manufacturer after 18 months from the date of production. The manufacturer does not have any control over the user's behaviour.	User manual	H
Eyesight damage by UV radiation.	Visor glass with protective layers to absorb UV radiation. The user manual indicates that the glass should be replaced if the protective coating is damaged.	EN 170:2005, section 4	M
Contact with flame and high temperature.	All components of the apparatus meet the flammability requirements of the standard. The protective apron of the apparatus is made of a non-flammable fabric (Kevlar) coated with aluminium.	EN 14594, section 6.9	H
<u>Risk related to placement of a faulty product on the market and to the use of the faulty product</u>			
Risk description	Methods and measures taken to avoid the incident	Reference	Risk assessment: Very high – VH High – H Medium – M Small – S Negligible – N
Placement of a faulty product on the market by the manufacturer	100% quality control of the apparatus, both at the intermediate and final stage. Minimal risk. Resin has a certified Quality Management System conforming to ISO 9001:2015.	ISO 9001	S
Recalling the faulty product from the market	Every apparatus (helmets) manufactured by Resin has a serial number to enable product identification and full traceability.	ISO 9001	S