

Operating Instructions

1-10DS

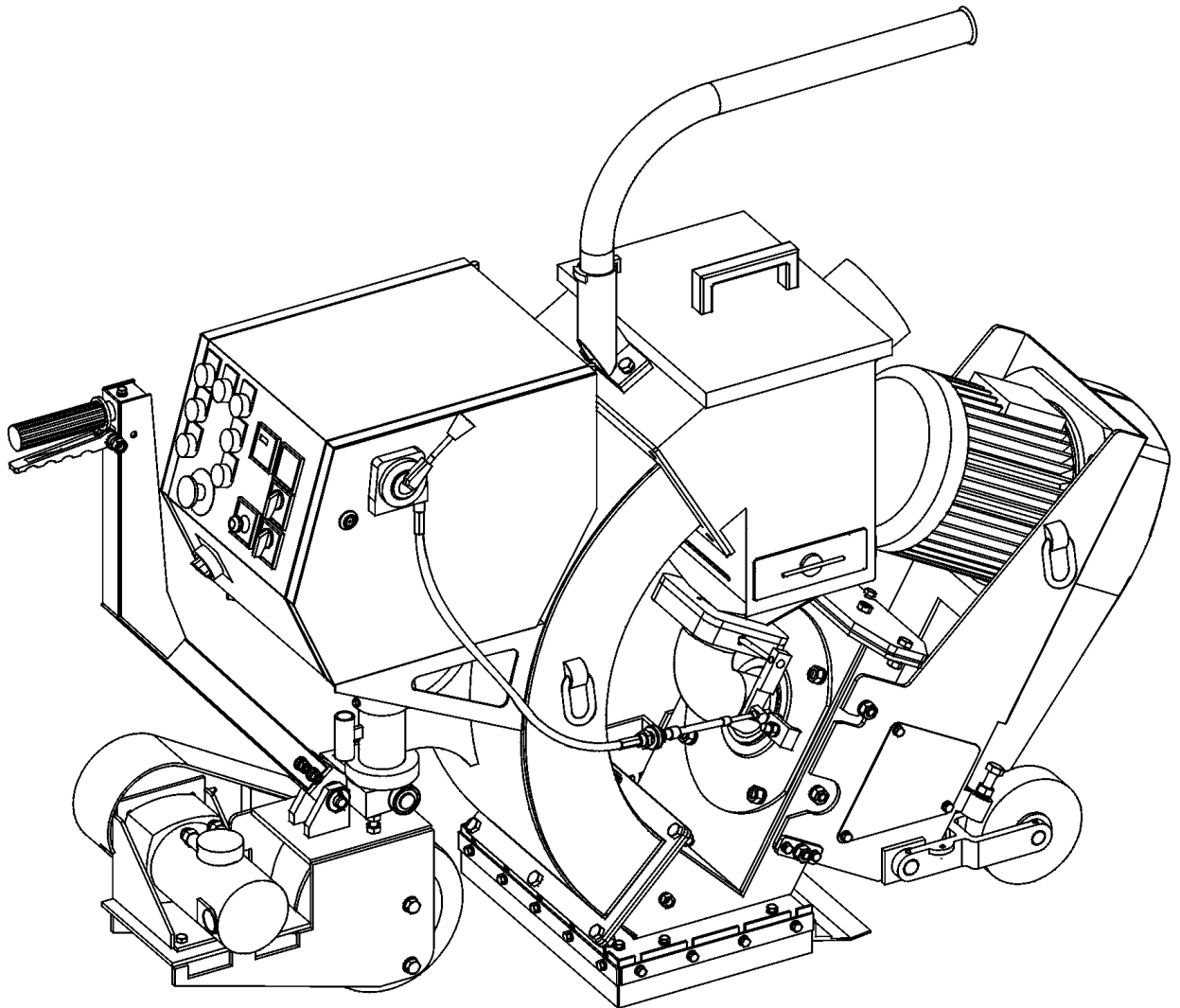

MAN-1-10DS-EN

USF BLASTRAC
EBE

USF Blastrac/EBE

Utrechthaven 12

3433 PN Nieuwegein

THE NETHERLANDS

T +31(0)30 - 601 88 66

F +31(0)30 - 601 83 33

E info@usfebe.nl

I www.usfebe.com



Technical data	1
Safety instructions	2
General	3
Transport	4
Initial operation	5
Operation	6
Maintenance	7
Electrical systems	8
Fault diagnosis	9
Spare parts	10

USF European Head-office

Surface Preparation

USF Blastrac

Poll-Vingster Straße 107

D-51105 Köln

T +49(0)221 -8394 -0

F +49(0)221 -8394 -666

E info@blastrac.de

USF Blastrac

P.O.Box 60, Craven Road,

Broadheath

Altrincham, Cheshire WA 14 5EP.

T +44(0) 16 19 28 63 88

F +44(0) 16 19 29 03 81

E usfsp@usfinternational.com

USF Blastrac

Zone Industrielle de Chasseneuil

29, Avenue des Temps Modernes

F-86360 Chasseneuil du Poitou

T +33(0) 5 49 00 49 20

F +33(0) 5 49 00 49 21

E usf.blastrac@wanadoo.fr

USF Blastrac

Pangborn Europe S.p.A.

Pangborn Europe S.p.A.

Via E. Fermi, 75,

Casella Postale No. 162

I-21042 Caronno-Pertusella (VA)

T +39 - 02 9 63 99 51

F +39 - 02 9 65 67 41

E pbeurope@pangborneurope.it

USF Surface Preparation Praha, s.r.o.

Dářská 516/12

CZ-198 00 Praha 9

T +420 2 818 660 09

F +420 2 818 68674

E m.hlavacek@mynet.cz

USF Blastrac

USF Surface Preparation Group Poland

ul. Wiertnicza 115

PL-02-952 Warszawa

T +48 - 22 651 70 91

F +48 - 22 651 70 92

E usfpol@ikp.com.pl

USF Surface Finishing

Belgium N.V.

Maalbeekweg 61

Airport Ring Center

B-1930 Zaventem

T +32 (2) 71 90 140

F +32 (2) 71 90 145

E usf@socomer.com

USF TTS

Calle Copérnico, 16 - Nave 2

E-28820 Coslada (Madrid)

T +34 - 91 660 10 65

F +34 - 91 672 72 11

E usf-tts@sarenet.es

USF Surface Preparation Group

Romania s.r.l.

Str. Muzeul Zambaccian Nr. 34, Sc. 1, Ap.1

RO-71722 Bucuresti

T +40 1 23 04 222

F +40 1 23 04 222

E usfspgro@xnet.ro

Contents Chapter 1

1.1 Rating

1.2 Unit specifications

1.3 Operative range and correct usage

1.4 Stand-by power supply (generator)

1.5 Machine type designation

1.6 Advice for operators of blast cleaning machines

Technical data**1.1 Rating**

Unit / designation	: USF Blastrac/EBE blast cleaning machine
Machine type	: 1-10 DS
Manufacturer	: USF Blastrac/EBE Utrechthaven 12 NL-3433PN Nieuwegein THE NETHERLANDS

1.2 Unit specifications

Dimensions:

	Machine 1-10DS	Dust collector 554 DC
Length	1650 mm	1800 mm
Width	425 mm	840 mm
Height	1100 mm	1200 mm
Weight	320 kg	450 kg

Connected loads (electrical system):

The indicated input current values correspond to the nominal current values of the motors working under full load. These values are not achieved under normal operating conditions.

	Power consumption	Input current
Blast wheel drive	11,0 kW	max. 20 A
Drive motor	0,22 kW	max. 1,8 A
Dust collector	5,55 kW	max. 12,0 A

Electrical connection required : 400 V, 50 Hz, 32 A, CEE plug

Technical data

	Rated speed	Enclosure
Drive of blast wheel	2900 min ⁻¹	IP 54
Drive of drive motor	2520 min ⁻¹	IP 55
Filter compressor	2850 min ⁻¹	IP 54
Filter fan	2890 min ⁻¹	IP 54

Blast wheel size	: 200	mm Ø
Working width	: 250	mm
Drive speed	: 0,5 - 20	m/min
Blast cleaning output	: up to 180	m ² /h on concrete
Dust hose connection	: 130	mm Ø
Recommended abrasive	: Media No. 2 - No. 5	
Abrasive consumption	: 100	g/m ²
Recommended filter unit	: 554 DC	

Technical data

1.3 Operative range and correct usage

1



The 1-10DS is exclusively designed to clean dry, frost-free horizontal surfaces. The machine may not be used for other purposes. The manufacturer will not be liable for damage resulting from such incorrect usage. In these cases the user assumes all risks.

1.4 Stand-by power supply (generator)



If the 1-10DS blast cleaning machine is operated using a generator, this generator must be operated in accordance with the current VDE directives (this applies to the protective earth conductor in particular) in order to ensure that all safety devices are functioning and to eliminate possible damage to electrical components.

1.5 Machine type designation

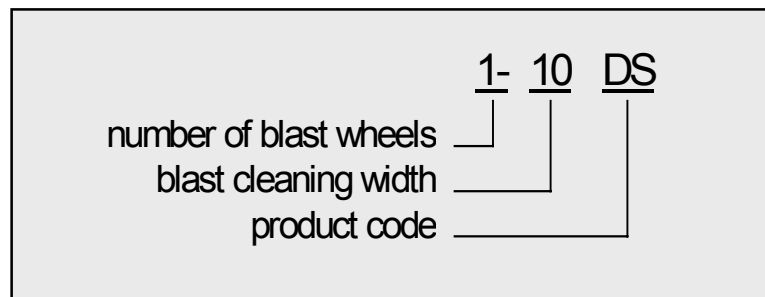

Technical data

1.6 Advise for operators of blast cleaning machines

In accordance with the accident prevention regulations for blast cleaning work (VBG 48) the operator must provide operating instructions for blast cleaning work in a form and language that is understandable.

The blast cleaning machine Operating Instructions are only part of these operating instructions. Please consult the current accident prevention regulations for the precise content.



1

During operation the acceptable noise level of the 1-10DS blast cleaning machine **could** exceed 90 dB(A). This noise level depends on the **local circumstances**. When the noise level is 90 dB(A) or more, the machine operator and persons working near the machine must wear sound-insulating equipment.



Safety instructions

Contents Chapter 2

- 2.0 Warnings and symbols
- 2.1 Organisational measures
- 2.2 Personnel selection and qualification
- 2.3 Safety precautions applicable to different operating conditions
- 2.4 Special work within the scope of use of the equipment and maintenance activities as well as repairs during operation
- 2.5 Definition of the **Safety off position**
- 2.6 Particular dangerous aspects of the equipment
- 2.7 Electrical engineering regulations



Safety instructions

2.0 Warnings and symbols

The following denominations and symbols are used in the Operating Instructions to highlight areas of particular importance:

2



Symbol of operational safety.

In these Operating Instructions this symbol will be shown next to all safety precautions that are to be taken in order to ensure prevention to life and injury. Follow these instructions and take special care in these circumstances. In addition to these instructions, the general safety precautions and accident prevention guidelines are also to be followed.



Particular details regarding the economical use of the equipment.



Information, instructions and restrictions with regard to possible risks to persons or to extensive material damages.

Safety instructions

Warning against dangerous voltages.



Indications relating to protective devices in electrical appliances.



2

Indications where consultation with the manufacturer is required.



Instructions relating to periodical checks.



Reference to important instructions contained in the Operating Instructions.



2.1 Organisational measures

The **Operating Instructions** are to be kept **near the location where the machine** is located and must be **within reach at all times!**



In addition to the Operating Instructions general and legal regulations regarding accident prevention and environmental protection must be complied with and indicated!

Such duties may for example relate to the handling of hazardous substances or to the provision and wearing of personal protection equipment as well as compliance with traffic regulations.

Safety instructions

The Operating Instructions must be **supplemented** by **instructions** including the duty to **supervise** and **report** relating to **particular working practices**, for example work organisation, work procedures and personnel allocation.

Personnel entrusted with working with the machine must have read the **Operating Instructions** before starting work, in particular the **Safety Instructions** chapter. To read these instructions during work is too late. This particularly applies to incidental activities such as setting up the equipment, carrying out maintenance work or training staff to work with the machine.

From time to time the working practices of the staff are to be checked regarding awareness of **safety and hazards**.

Personnel must tie back long hair and not wear loose clothing or jewellery including rings. There is a risk of injury through getting stuck or being drawn into moving machinery.

2



Use **personnel protection equipment** if necessary or required by regulations! Take notice of **all** safety and hazard notices on the machine!

All **safety and hazard notices** at or on the machine must be kept complete and **legible**!

If **safety-critical changes** occur to the machine or its working method, the machine must be **shut down immediately**! The cause of the fault must be established immediately!



Changes, add-ons or conversions to the machine which might impair safety must not be undertaken **without the manufacturer's permission**!

This applies in particular to the fitting and adjustment of safety devices as well as to welding on load-bearing parts.

Spare parts must comply with the technical requirements specified by the manufacturer. This is always guaranteed if original spare parts are used.

Intervals for recurring **checks and inspections** specified in these Operating Instructions must be complied with!

Safety instructions

To perform maintenance work correctly it is imperative to be equipped with the proper tools for the task in question.

The **location** and the operation of **fire extinguishers** must be made known on each building site!

Take note of the facilities for reporting and fighting fires!

2

2.2 Personnel selection and qualification

Fundamental duties :

Work on the machine may only be undertaken by **reliable personnel**.

Only trained personnel may be deployed. **Note the statutory minimum age!** Specify clearly the responsibilities of personnel for operation, setting up, servicing and maintenance work!

Make sure that only **authorised** personnel operate or work on the machine!

Define responsibilities of the machine operator also regarding to **traffic safety regulations** and empower him to decline instructions from third parties which are not complying with the safety requirements!

Personnel being trained or made acquainted with the equipment may only be deployed on the machine **under constant supervision of an experienced person!**

2.3 Safety precautions applicable to different operating conditions

Ban any method of working that **impairs safety!**

Safety instructions



Only operate the machine when all **safety devices** and related **safety equipment**, e.g. detachable **safety devices**, emergency stops and suction devices are present and **operational!**

2

Check the machine visually for any **damage** and **defects** at least once a day!

In the event of **operational malfunctions** the machine must be **shut down immediately** and secured, and the fault must be rectified!



Secure the **work area** around the machine in **public areas** providing a **safety distance** of at least 2m from the machine.

Before switching on the machine make sure that no-one can be endangered when the machine starts up!

Do not switch off or remove the exhaust and ventilation devices when the machine is running!



All persons in the proximity of the machine must wear safety glasses with lateral protection as well as safety shoes. The operator is obliged to wear close-fitting protective clothing.



Use only extension cable for extending the main cable that are sized and marked in accordance with the overall power consumption of the machine and the valid VDE guidelines.

2.4 Special work within the scope of use of the equipment and maintenance activities as well as repairs during operation

Mechanical servicing work:

Safety instructions

Put the machine in the **Safety off position** as described in chapter 2.5 for any servicing work on the machine in order to prevent the machine from being **switched on** accidentally.

Please follow any special **safety instructions** in the various chapters on servicing the machine.

See chapter 7.1 - 7.19.

Adjustment, servicing and inspection work and time limits specified in these Operating Instructions as well as any information on the replacement of parts and equipment must be **undertaken and/or complied with!**

These activities may only be undertaken by **qualified personnel**.

Do not use any **aggressive** cleaning materials!
Use lint-free **cleaning cloths!**

Always tighten any screw connections that are undone during servicing and maintenance work!

If **safety devices** need to be **dismantled** during setting up, servicing and repairs, these **safety devices** must be **reinstalled** and inspected immediately after completion of the servicing and repair work.

Make sure that process materials and replaced parts are disposed of safely and in an environmentally-friendly manner!

Electrical servicing work:

Make sure that electrical components used for replacement purposes comply with the original parts and are correctly adjusted if necessary.

For safety notes see 2.7 Electrical engineering regulations.

2.5 Definition of the Safety off position

Definition:

The machine is in a safe condition when it cannot generate any hazard.

Safety instructions

Putting the equipment in the Safety off position means:

- ☑ **Close the magnetic valve.**
- ☑ **Switch of the blast machine.**
- ☑ **Switch off the dust collector.**
- ☑ **Wait for standstill of all drives.**
- ☑ **Pull out mains plug.**

2

2.6 Particular dangerous aspects of the equipment



Any machine, if it is **not used according the regulations**, may be **hazardous** for operating, setting-up and service personnel. The **operating authority** is responsible for **compliance with the safety regulations** during operation and maintenance of **safety devices** supplied with the machine as well as the provision of appropriate additional safety devices!

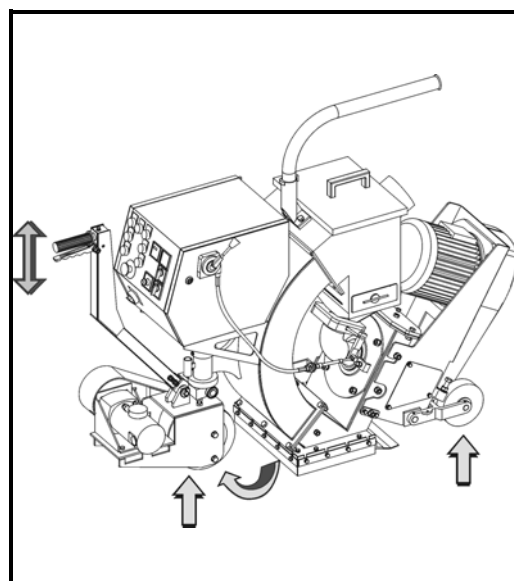

1. Blast housing outlet

Danger of injury!

Abrasive leaves housing with high speed!
Moving parts!

Lift and cant the machine only when it is in Safety off position.

It is not allowed to stay within the working radius of the machine!

Safety instructions

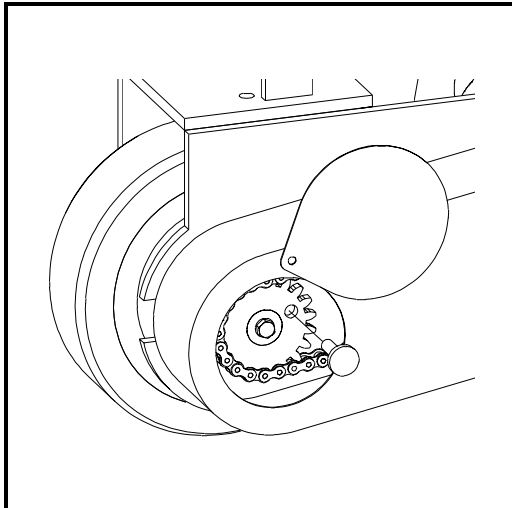

2. Drive assembly, quick release pin

Danger of injury!
Moving parts!

Be very careful with inserting the quick release pin.

Only authorised personnel may operate the machine!

2

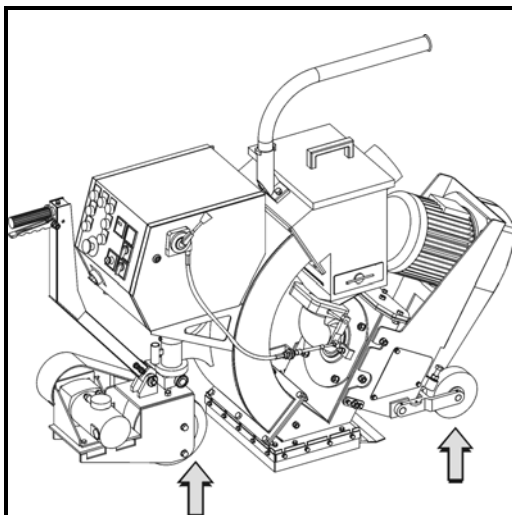

3. Wheels

Danger of injury!

Moving parts!

It is not allowed to stay within the working radius of the machine!

2.7 Electrical engineering regulations

Work on **electrical** equipment or operating materials may only be undertaken by a **skilled electrician** or by **trained** persons under the **guidance** and **supervision** of a **skilled electrician** as well as in accordance with the **electrical engineering regulations**.



Use only extension cable for extending the main cable that are sized and marked in accordance with the overall power consumption of the machine and the valid VDE guidelines.



Safety instructions



The electrical equipment for the plant must **inspected regularly**. Please note in particular the ***specified recurring inspections*** according **EN60204-1**. Defects such as **loose** connections or **scorched** cables must be rectified **immediately**. **Call a skilled electrician or our Customer Services**.

2

A **second** person must be deployed who can pull out the plug in an emergency if work on **live** parts is necessary. The work area must be sealed off using a red and white **safety chain** and a danger sign. Use a tool that is **insulated against voltages**.

Only start work once you are familiar with the **electrical engineering regulations** that apply to your area.

Only use voltage seekers that **comply with the regulations** when troubleshooting. From time to time check voltage seekers to ensure that they are operationally efficient.

Contents Chapter 3

- 3.1 Introduction
- 3.2 Operating instructions
- 3.3 Connections
- 3.4 Care and maintenance
- 3.5 Scope of supply
- 3.6 Description
- 3.7 Control box
- 3.8 Operating elements
- 3.9 Blast wheel
- 3.10 Separator
- 3.11 Drive mechanism
- 3.12 Abrasive sealing
- 3.13 Air suction and filter system
- 3.14 Abrasive media

General**3.1 Introduction**

USF Blastrac/EBE wants to thank you for your decision to employ the blast cleaning machine 1-10DS for the treatment of horizontal surfaces.

The machine has a closed abrasive circuit with dust separation. This comprehensively avoids damaging the environment and endangering the operating staff.

The 1-10DS is designed to remove coatings, bitumen and asphalt on different types of horizontal surfaces.

3.2 Operating instructions

This manual has been written to support the operating personnel on learning the functioning of the machine and to guarantee optimum operation and maintenance.



Therefore it is important that all persons operating and maintaining the machine read this manual carefully and understand it fully.

The supplied machine has been manufactured for being employed in the user's country. All descriptions and notes have been formulated in the language of the user's country or in English in accordance with the statutory regulations, or shown as pictograms. If the customer deploys personnel with little knowledge of the language of the user's country, appropriate instruction and training must be provided.



Before using the machine personnel must be familiar with how to operate the machine, with all important components, with the method of working and with its dimensions.



USF Blastrac/EBE offers a course on the use of the machine in order to make the operating and maintenance personnel familiar with all elements of the blast cleaning machine.

General

Initial commissioning of the machine must be carried out very carefully. The machine operator must fully understand the sequence of commissioning of the individual parts and their functioning.



All persons in the proximity of the machine in operation must wear safety glasses with lateral protection and safety shoes. The machine operator must wear close-fitting protective clothing.

**3.3 Connections**

Voltage	Connection type	Power consumption	Operating current
400V 50Hz	CEE-plug 32A	approx. 12 kW	approx. 20 A

3.4 Care and maintenance

Special attendance and regular maintenance of the machine and its parts are imperative for functioning and safety.

In order to prevent unnecessary downtimes it is recommended to keep original spare and wear parts on stock as listed in the maintenance box.

A list of contents of the maintenance box is provided in Chapter 10 to enable the above-mentioned work to be carried out quickly.



General

3.5 Scope of supply

Scope of supply of the machine:

- Blast cleaning machine (1-10DS)
- Filter unit (554 DC)
- Dust hose
- Operating instructions (2 x)
- Maintenance box (option)
- Magnetic broom (option)

3.6 Description

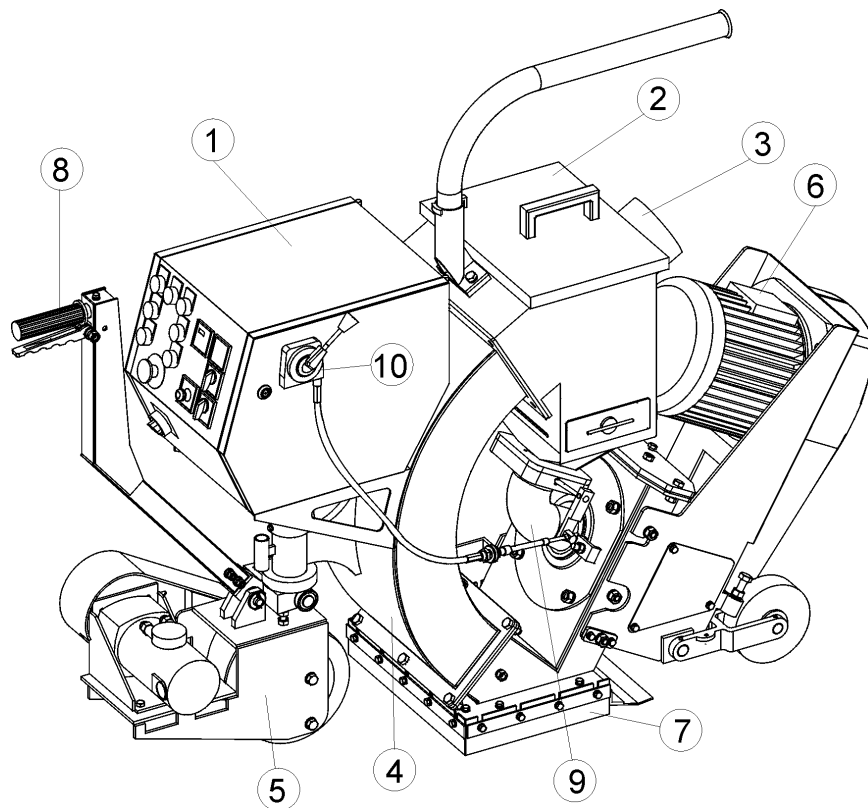

Fig. 3.1

- | | | | |
|---|-------------------|----|------------------------------------|
| 1 | Control box | 6 | Blast wheel motor |
| 2 | Separator | 7 | Blast head, magnets, brush sealing |
| 3 | Filter connection | 8 | Dead man's handle |
| 4 | Rebound plenum | 9 | Feed spout |
| 5 | Drive mechanism | 10 | Abrasive control handle |

The **USF Blastrac/EBE** blast cleaning machine 1-10DS is a downward blasting machine with a closed abrasive circuit designed for the pre-treatment of horizontal surfaces. The bouncing impact of metallic abrasive onto the surface to be treated thoroughly removes surface contaminants, coats of paint, sealants and thin coatings. Like many revolutionary inventions the blast wheel method is based on a simple principle: after mechanical pre-acceleration the abrasive is thrown onto the surface at high speed by the blast wheel. Once the abrasive has impacted on the surface it rebounds into a rebound plenum. The rebound plenum deflects the abrasive into an air current separator. Here dust and other contaminants are removed from the abrasive so that only abrasive containing a very small amount of dust is fed into the abrasive storage hopper for re-use by the blast wheel.

A suitable filter unit must be connected to the machine in order to separate the dust from the abrasive.

A specially designed dust collection system ensures dust-free operation of the machine and clean air at the workspace.



Fig. 3.2

General

3.7 Control box

The control box is equipped with all control elements and instruments for monitoring and controlling the blast cleaning machine.

3

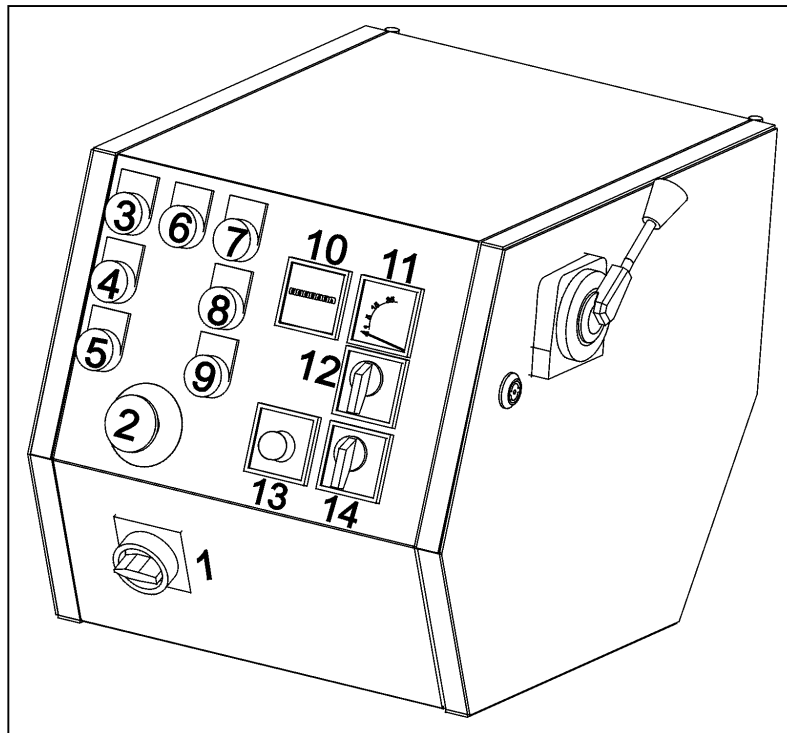

Fig. 3.3

- | | | | |
|---|---------------------------------|----|-----------------------------------|
| 1 | Main switch | 8 | Push button "Blast wheel ON" |
| 2 | Emergency shutdown switch | 9 | Push button "Blast wheel OFF" |
| 3 | Control lamp "Control" | 10 | Hour counter |
| 4 | Push button "Control ON" | 11 | Ammeter |
| 5 | Push button "Control OFF" | 12 | Selection switch fast drive |
| 6 | Control lamp "Motor protection" | 13 | Drive speed control |
| 7 | Control lamp "Blast wheel" | 14 | Selection switch forward/backward |

Main switch

The main switch is located on the control box. It has to be switched on before operation.

General

Emergency shutdown switch

The emergency shutdown is a red mushroom-shaped press switch on a yellow background. Pressing this switch immediately interrupts power supply to all machine components.

Push buttons "Control ON/OFF", Control lamp

Pressing the push button "Control ON" switches the control on and makes the control lamp light up. Pressing the push button "Control OFF" switches the control off.



Push buttons "Blast wheel ON/OFF", Control lamp

Pressing the push button "Blast wheel ON" switches the blast wheel motor on and makes the white control lamp light up. Pressing the push button "Blast wheel OFF" cuts off the motor power supply immediately.

Control lamp motor protection

This red control lamp lights up when the complete electronics has been switched off by overload of one of the motors. As long as the control is not switched on again this lamp will light.

Selection switch forward/backward

This switch controls the direction of the drive motor.
Position "2" - Blast cleaning direction of movement backwards
Position "1" - Move forward direction

Selection switch fast drive

This switch bypasses the drive speed control and the machine will travel at top speed.

Drive speed control

Although this indication does not allow direct reading of the actual speed, it shows comparing numbers allowing the operator to set the appropriate speed.

General

Ammeter

The ammeter shows the load consumption of the blast wheel motor. When switching on the motor the current value is high (starting current peak) and falls, after having reached the idle speed, to approximately 7A. With full load it may rise to a maximum of 20 A.

Hour counter

The hour counter shows the sum of the actual working hours performed by the blast wheel.

3.8 Operating elements

The abrasive valve

Between the abrasive storage hopper and the feed spout there is a valve incorporating a permanent magnet in order to control the abrasive flow towards the blast wheels. Any change in the opening of the magnetic valve causes the amount of abrasive fed to the blast wheel to change. The change in the abrasive fed can be read from the ammeter. The valve is hand-operated and can be adjusted so that any quantity of abrasive can be fed to the blast wheel. Optimum blast cleaning power is reached when the ammeter indicates the operating current (20A). It is not permitted to blast with a higher current value.

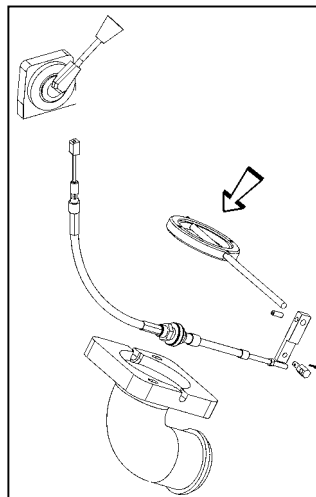

Fig. 3.4

General**Abrasive control lever**

This lever is located on the control box and regulates the magnetic valve to control the flow of abrasive towards the blast wheel. The valve is hand-operated and can be set to each amount of abrasive throughput by changing the lever position.

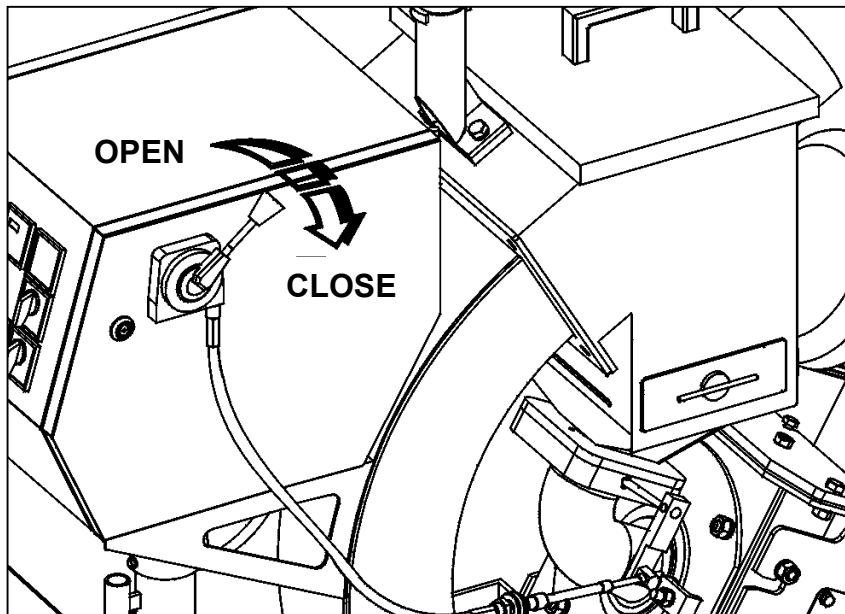

Fig. 3.5

Abrasive control OPEN / CLOSE

On/Off switch Drive motor

The switch lever (1) below the control handle serves for controlling the drive motor. Actuating the switch lever closes the power circuit to switch on the drive motor. When the lever is released the drive motor switches off (dead man's handle).

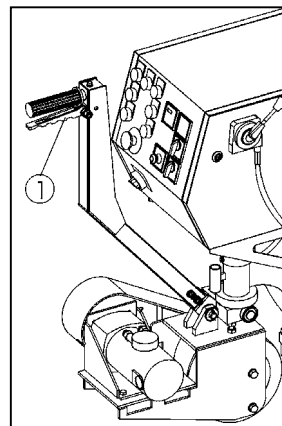

Fig. 3.6

General

3.9 Blast wheel

The heart of the blast cleaning machine is the blast wheel which throws the abrasive onto the surface to be cleaned by using centrifugal force. The blast wheel is placed in a protective housing lined with replaceable wear plates. The blast wheel is driven by an electric motor.

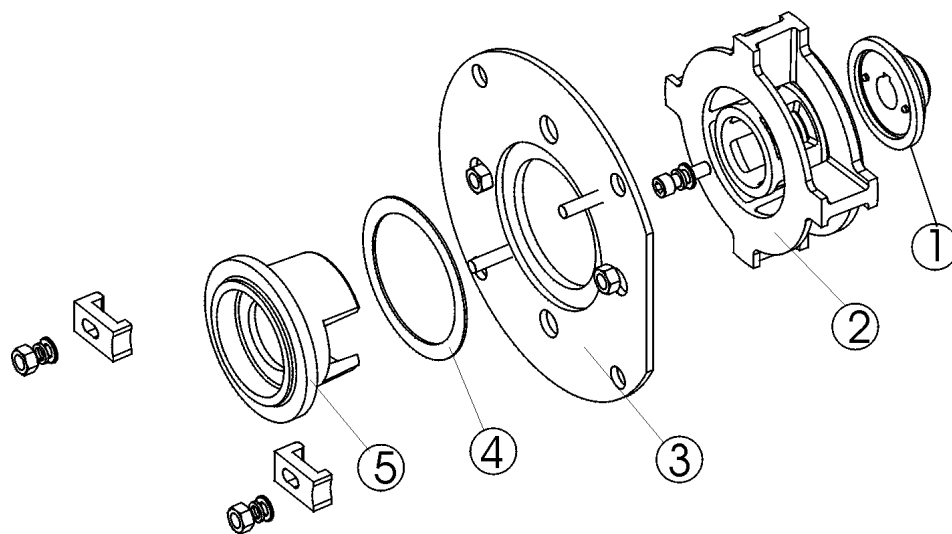

Fig. 3.7

Around the centre of the blast wheel there is the impeller (4 notches) feeding dosed quantities of abrasive onto the blades of the turning blast wheel. On top of this is the control cage which, once it is carefully set, regulates the flow of abrasive.

- 1 Wheel hub
- 2 Blast wheel
- 3 Blast wheel cover plate
- 4 Control cage shim
- 5 Control cage

3.10 Separator

The abrasive separator is mounted to the end of the rebound plenum. It separates the abrasive from contaminants and feeds the cleaned abrasive back to the abrasive circuit.

A wire mesh is fitted to prevent any coarse contaminants from getting into the blast wheel. In order to clean the wire mesh drawer the separator cover can be removed or the wire mesh drawer can be removed from the side.

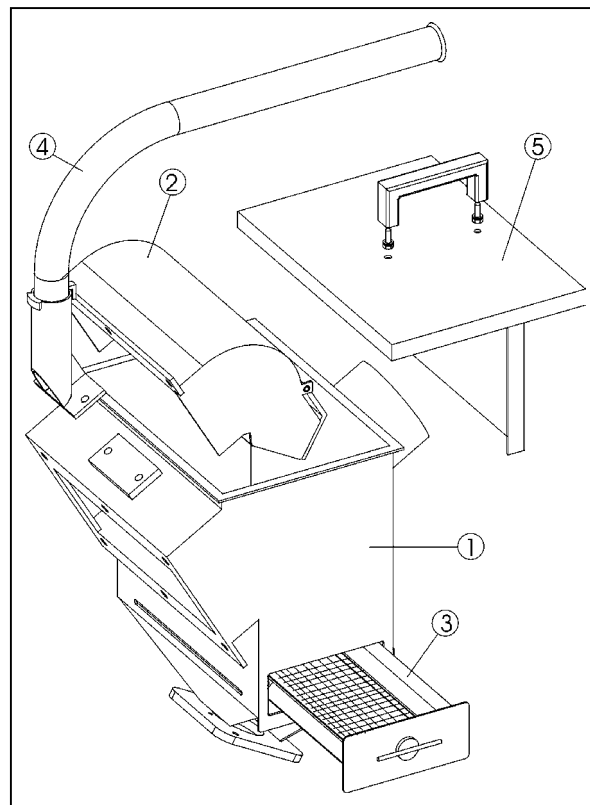

Fig. 3.8

- 1 Separator
- 2 Deflector
- 3 Separator drawer (wire mesh)
- 4 Cable guide
- 5 Separator cover

General

3.11 Drive mechanism

The machine 1-10DS is driven by a 0,22 kW electric drive motor. The power is transmitted via a chain drive. The drive wheel and the chain disk are not linked rigidly. They are only linked after insertion of the quick release pin.

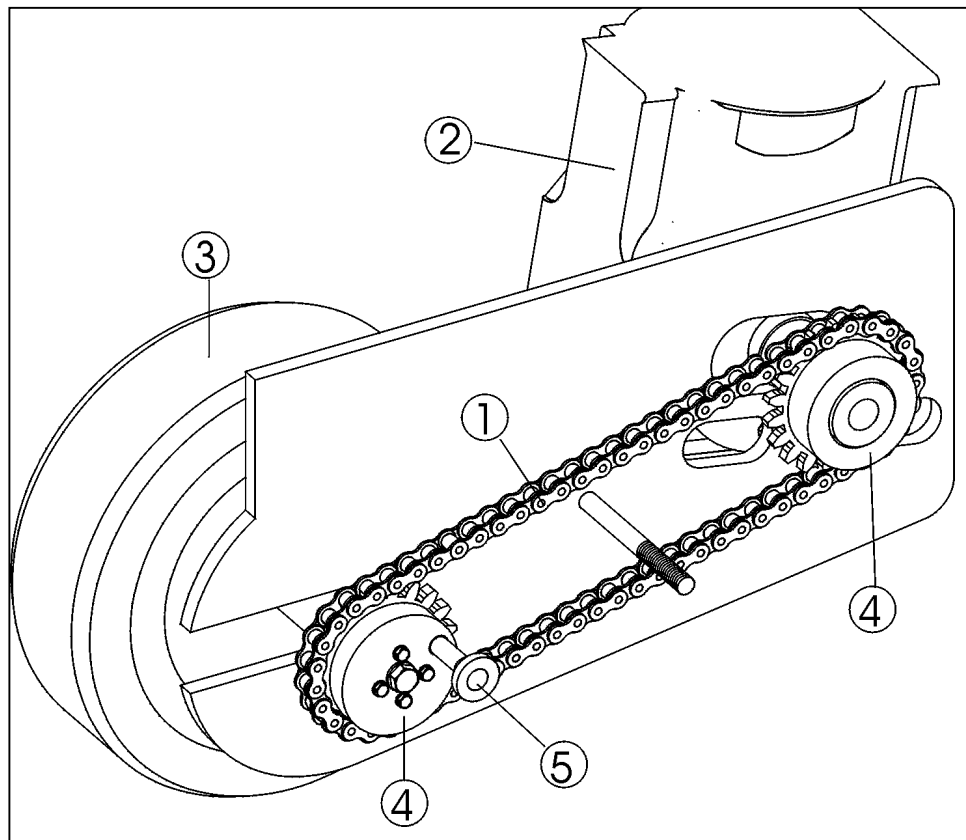

Fig. 3.9

- 1 Chain drive
- 2 Drive motor
- 3 Drive wheel
- 4 Chain disks
- 5 Quick release pin

3

3.12 Abrasive sealing

Magnetic seals are fitted to the front and the sides of the blast housing outlet and are surrounded by brush seals. At the rear there are two seals sliding over the floor.

The seals are employed to seal the blasting area in a way to avoid leakage of any abrasive.

The correct height adjustment of the magnetic seals (8-10 mm) is very important for optimum functionality of the machine. The adjustment can be carried out by means of setting screws on the wheels and on the drive mechanism of the machine.

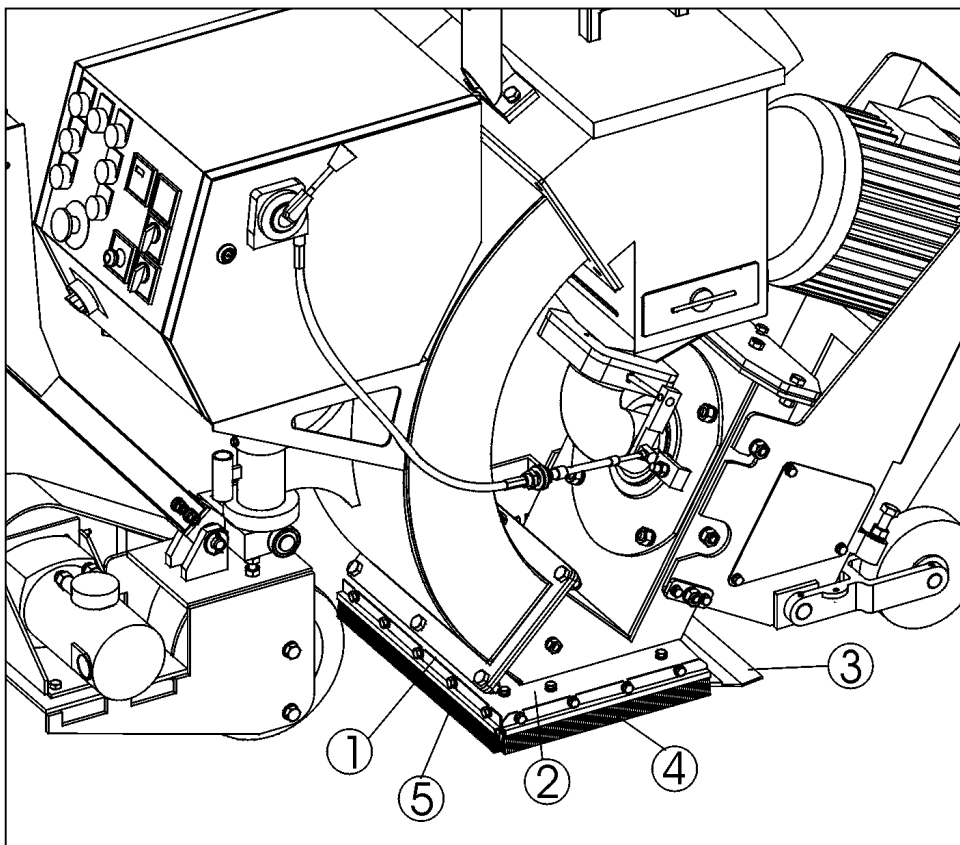

Fig. 3.10

- 1 Front magnet
- 2 Side magnet
- 3 Rear seal
- 4 Side brush
- 5 Front brush

General**3.13 Air suction and filter system**

The sucked-in air streaming through the complete system when the blast cleaning machine and the filter unit are in operation has the following functions:

- Cooling of the blast wheel
- Cooling of the abrasive
- Transport of the abrasive
- Transport of dust through the system
- Separation of dust from the re-useable abrasive
- Transport of dust to the filter unit

Motor output : 4 kW
Air throughput : 765 m³/h
Connector cable length : 15 m

Dust hose
Length : 15 m
Diameter : 130 mm



The correct height adjustment of the machine (8-10 mm) is of utmost importance. There must be no leaks in the blast housing, at the control cage and in the dust separator.

All connection points must be sealed carefully and the dust hose must be fixed with hose clamps!

The filter housing must be sealed properly and all sealings must be in good condition!

If dust leaves the filter unit instead of clean air, this is a sign that the filter cartridges are either damaged or not fixed correctly inside the filter chamber.

The air streams through the machine as follows:

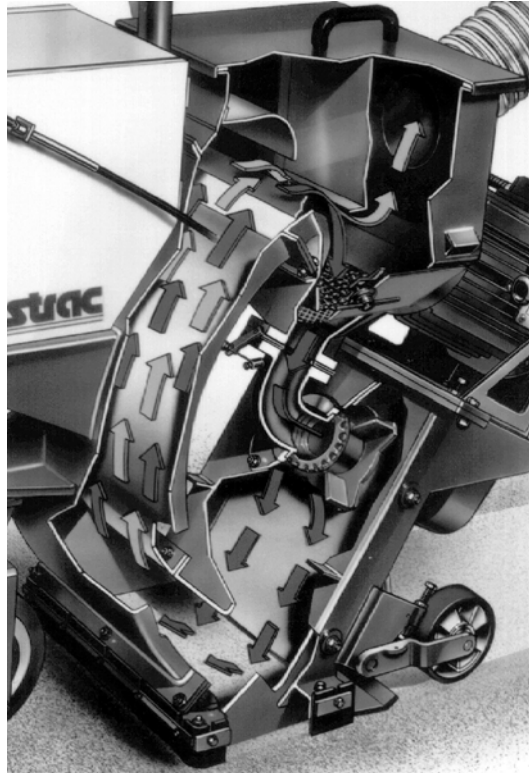

Fig. 3.11

- Air is sucked in at the rear seal and carries along abrasive and dust.
- The air stream flows through the rebound plenum and carries along abrasive and dust. In doing so the air stream cools the abrasive and the housing walls.
- The air enters the separator, separates the fine dust from the abrasive and transports the dust to the outlet opening. The separator cover must be closed air-tight in order to grant an optimum performance of the separator.
- The air stream then flows through the approx. 20 m long flexible dust hose taking dust and fine particles with it.

General

- ❑ The air stream now enters the filter chamber of the filter unit where the dust and the fine particles are separated from the air. The cleaned air is then fed into the environment again.

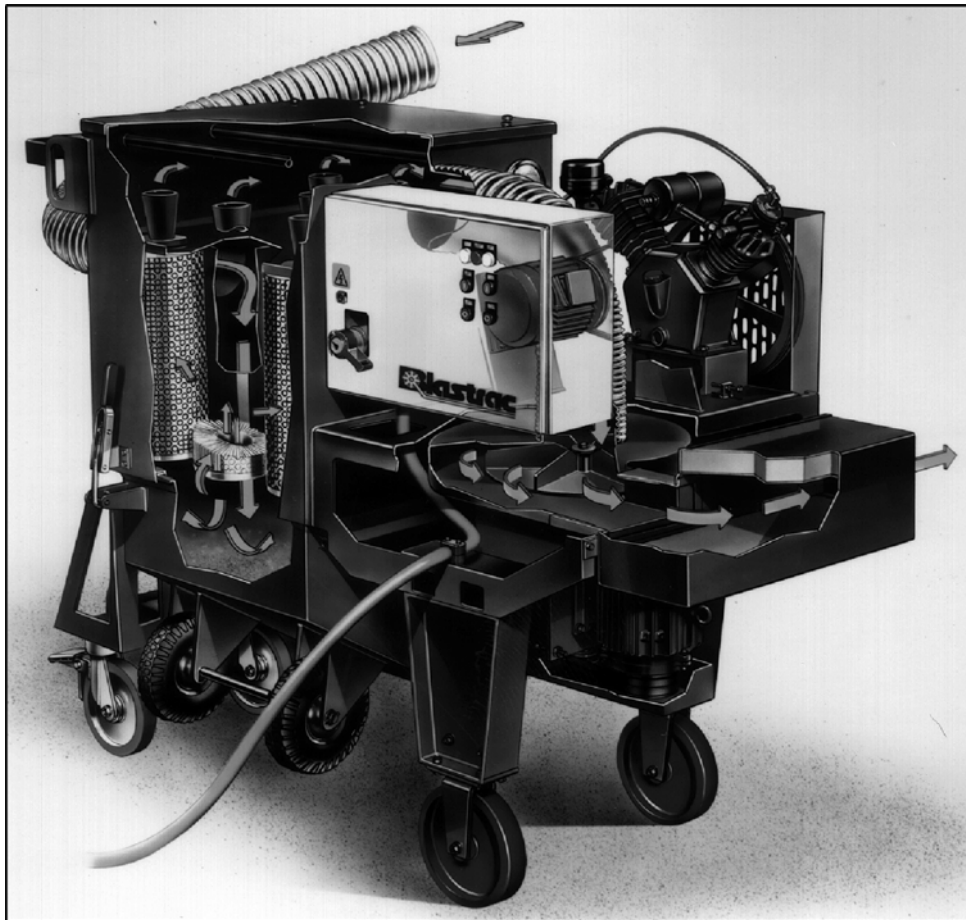

Fig. 3.12

3.14 Abrasive media

In order to operate the **USF Blastrac/EBE** machine 1-10DS you need hardened, spherical abrasive. The machine 1-10DS has been especially designed to be operated with **USF Blastrac/EBE** abrasive.

The **USF Blastrac/EBE** abrasive is of very high quality and owns the rebounding ability required for the efficient use of the 1-10DS. The selection of the abrasive is very important since this is the material to carry out the surface treatment.

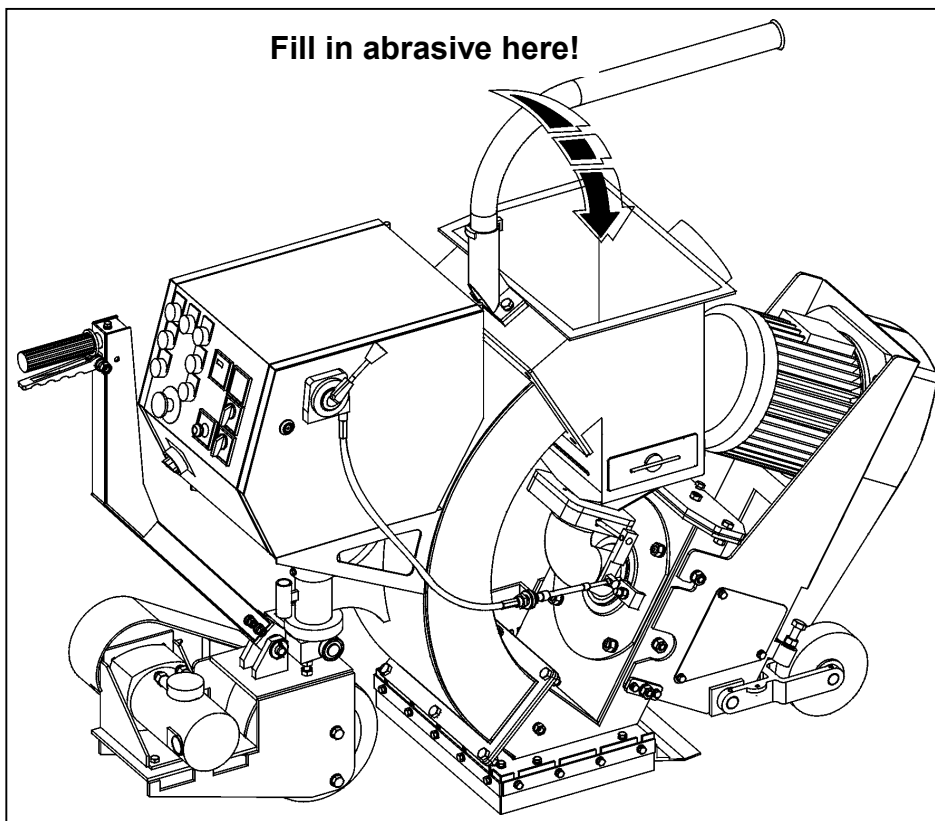

Fig. 3.13

General

Selection of abrasive

Media No. 2:

Applications:

- creates fine profiles, e.g. on vacuum concrete and non-glazed tiles
- removes thin layers of paint

Is often used when the surface is only subsequently sealed.

Media No. 3:

Applications:

- creates a fine to medium texture on concrete
- removes glazing from tiles prior to subsequently coating with antiskid floor sealings
- removes old impregnations and coatings about 1 mm thick

Media No. 4:

Standard abrasive, suitable for about 50-60 % of all applications. Creates a medium profile on concrete. Fulfills the same purpose as Media No. 3 when a higher speed of the machine is required, e.g. on asphalt, in order to keep the thermal load low.

Applications:

- removes laitance from new concrete
- roughening of smooth concrete or natural stone
- removes coatings with a thickness of 1-3 mm and cleaning of steel surfaces

Media No. 5:

This media is used to create a coarse profile or to increase the work speed in the case of surfaces hard to treat.

Applications:

- removes sediments on concrete prior to coating
- removes thick paint coatings or rust from steel surfaces, bridges, tanks, etc.
- removes flexible coatings on parking house decks
- removes road markings and retexturing of asphalt and concrete roads

**Media No. 8:**

Only as an **addition** to Media No. 3, No. 4 and No. 5 with **maximum** 30% content.

Applications:

- removes polyurethane coatings
- removes adhesive remnants
- removes rubber deposits
- penetrates coatings hard to remove
- also suitable to be used on steel

General

Media No. 8 should never be used without blending since otherwise the wear in the machine as a whole would increase disproportionately.

The effectiveness of the 1-10DS depends on the rebound effect which ensures that the abrasive can be re-used.

Please take into account that the use of incorrect abrasive increases wear.

Our service engineers have the experience to select the appropriate abrasive for the individual cases of application.

Please consult our local **USF Blastrac/EBE** customer service department if you have any questions about the selection of the best abrasive for your blast cleaning work.

USF Blastrac/EBE Media No. 2 - S00002
USF Blastrac/EBE Media No. 3 - S00003
USF Blastrac/EBE Media No. 4 - S00004
USF Blastrac/EBE Media No. 5 - S00005
USF Blastrac/EBE Media No. 8 - S00008

3



Contents Chapter 4

- 4.1 General notes
- 4.2 Transport
- 4.3 Operation conditions
- 4.4 Operation
- 4.5 Unit specifications



Transport

4.1 General notes



Before the machine is used for the first time, **USF Blastrac/EBE** authorised dealers offer a course to familiarise maintenance and operating personnel with all elements of the machine. We are not liable for damage caused by incorrect use of the machine by personnel not trained by **USF Blastrac/EBE**.

4.2 Transport

When transporting the machine proceed in such a manner that damage due to the effects of the use of force or incorrect loading and unloading is avoided.

4



Remove the abrasive from the machine before it is transported. The weight and dimensions of the machine are shown in Chapter 1 "Technical data".

The machine is to be transported after being separated into:

- Machine
- Filter unit (554 DC)
- General accessories

4.3 Operation conditions

Check the surface to be treated for loose parts (stones, screws, etc.). The surface must be swept if necessary. Make sure that the machine can travel over all inequalities on the surface. Small inequalities like weld seams or floor joints are no barriers for the machine.

4.4 Operation

The machine is operated in accordance with the instructions given in Chapter 5 "Initial operation".

Whenever the machine is not used for blast cleaning, the abrasive valve must always be closed!



Please note that the illustrations are simplified.

4.5 Unit specifications

The main dimensions and unit specifications of the machine when assembled are shown in Chapter 1 "Technical data".



Initial operation

Contents Chapter 5

5.1 Preparations for initial operation

5.2 Initial operation

Initial operation

5.1 Preparations for initial operation

Before switching on make sure that all existing protective housings are mounted and that the filter unit is connected correctly.



All persons in the proximity of the machine must wear safety glasses with lateral protection as well as safety shoes. The operator is obliged to wear close-fitting protective clothing.



Handle all plugs, cables, hoses and operating devices with care. Avoid any contact with live wires.

Works on the electrical system must only be carried out by qualified specialists.

Check the surface to be treated for loose parts (stones, screws, etc.). The surface must be swept if necessary. Make sure that the machine can travel over all inequalities on the surface. Small inequalities like weld seams or floor joints are no barriers for the machine.

5



Regular inspection is important in order to avoid downtimes. Carry out the following checks before any start-up:

- ☑ Check whether all machine parts are assembled safely and correctly.
- ☑ Check all screws and other fasteners for tight seat.
- ☑ Check the abrasive storage hopper, the feed spout and the blast wheel parts for foreign bodies and remove them.
- ☑ Check the blast wheel blades, impeller, control cage, liners and fastening screws for damages and wear.
- ☑ Check the magnetic and brush seals for wear.

Initial operation

- ☑ Lubricate the wheel bearings of the drive wheel every 100 working hours.
- ☑ Check the tightness of the hose connections and the condition of the hose to the filter.
- ☑ Make sure the dust container of the filter unit is empty. Please comply with the local waste treatment regulations considering the removed material.
- ☑ Check the separator parts for wear and defects. Remove foreign bodies and dust deposits in order to prevent the separator from being blocked.
- ☑ Check the electrical connections for dirt and foreign body deposits.
- ☑ Check the electrical motors for dirt and other contaminants.
- ☑ Check the level of abrasive in the storage hopper. Refill if necessary.

Initial operation



Before start-up the operating personnel must be familiar with the safety regulations given in this manual.

- ☑ Place the blast cleaning machine and the filter unit onto the surface to be treated. Remove the quick release pin in order to drive the machine manually.
- ☑ Check the height adjustment (approx. 8 - 10 mm) of the blast cleaning machine.

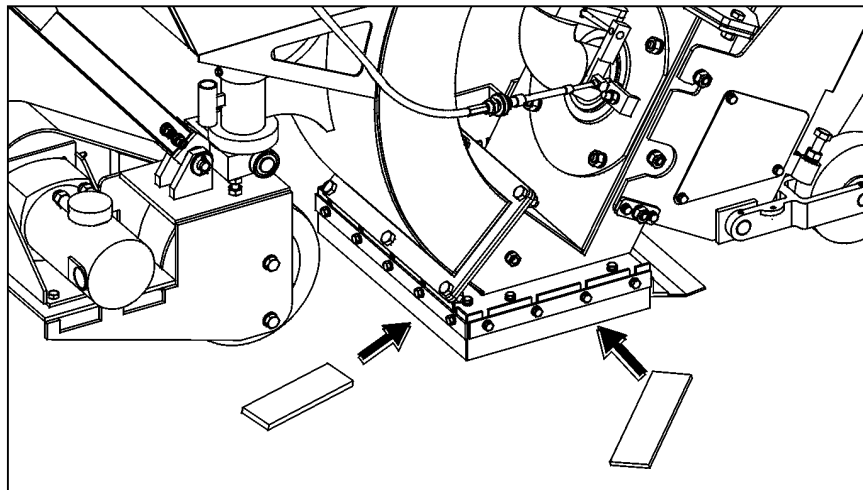

Fig. 5.1

- ☑ For the height adjustment, a 8-10 mm sheet steel strip is shifted below the magnetic sealing.
- ☑ Check the main power cable and the dust hose for damage. Replace or repair all damaged parts before starting the machine.
- ☑ Connect the blast cleaning machine and the filter unit with the dust hose. Use hose clamps at the connections.

5

Initial operation

- ☑ Connect the supply cable of the blast cleaning machine with the filter unit.
- ☑ Connect the supply cable of the filter unit with the site supply. Make sure that the correct electric supply is available (400V, 50Hz, 32A for CEE-plug).

Check the functionality of the fault current breaker by pressing the test push button!



- ☑ Fill the separator equally with the selected abrasive (see Chapter 3.14) up to the bottom of the separator tray. The magnetic valve must be closed whilst doing this.

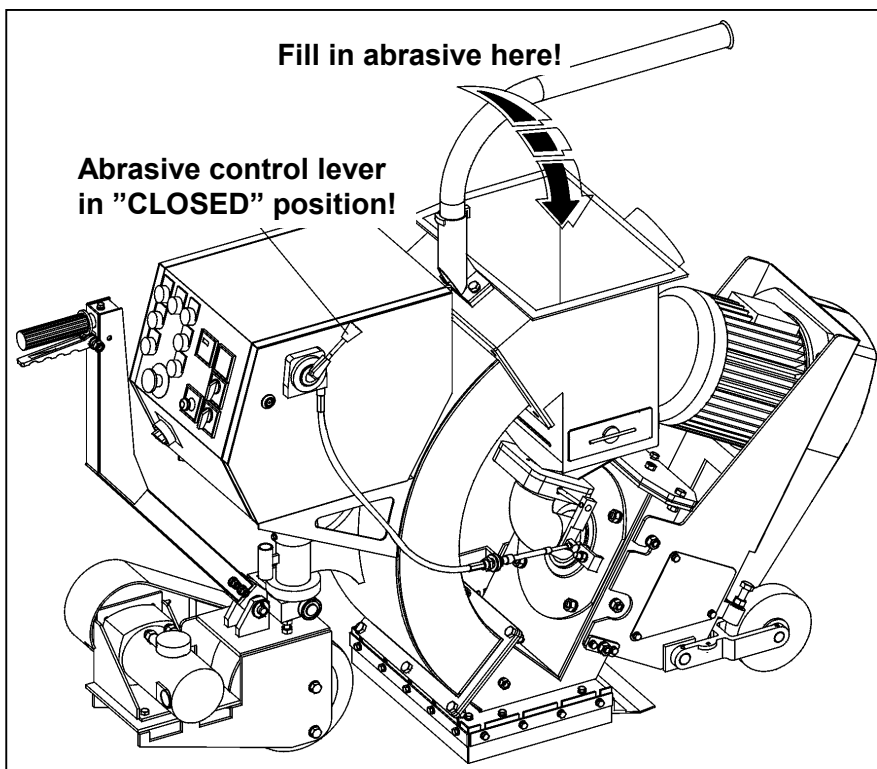

Fig. 5.2

- ☑ Check that the filter dust container has been emptied. Please comply with the local waste treatment regulations considering the removed material.

Initial operation**5.2 Initial operation**

All persons in the proximity of the machine must wear safety glasses with lateral protection, ear protection as well as safety shoes. The operator is obliged to wear close-fitting protective clothing.

The start of the blast cleaning machine and the filter unit is effected in the following sequence:

1 Switching on the filter unit

- Main switch of the filter unit "ON"
- Compressor "ON"
- Fan "ON"
- Check the turning direction of the filter and compressor motor

The correct turning direction is indicated by the arrow on the belt guard.

Correction of the turning direction of the drive motors

- Switch off the drives
- Switch off the main switch
- Open the control box on the filter unit
- Set the reversing switch 1SQ to the opposite position
- Close the control box
- Check the turning direction of the drives again

Initial operation

2 Initial operation of the blast cleaning machine

- Check that the magnetic valve is closed (black lever in position "CLOSED" Fig. 5.2).
- Check that the emergency shutdown switch is not actuated.
- Switch the main switch of the machine to "ON".
- Press the push button "Control ON".

Inserting the quick release pin

- Open the cover at the chain guard of the travel drive.
- Set the switch "Fast drive" to "OFF". Turn the potentiometer to position 1 (lowest speed).
- Keep the spring pressure button pressed down and insert the quick release pin into the bore of the chain disk.
- Actuate the drive switch. The chain disk starts to turn. Push the quick release pin slightly until it locks. The machine is now driven by the travel motor.
- Close the cover at the chain guard of the travel drive.

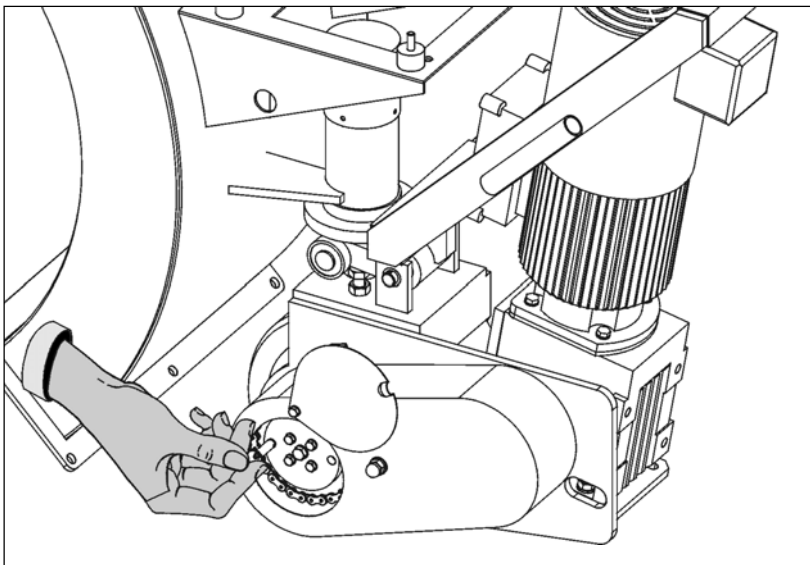

Fig. 5.3

Initial operation

- Press the push button "Blast wheel ON". The blast wheel motor is started.
- Observe the ammeter in order to check the power consumption of the blast wheel motor. The motor requires a lot of power (starting current) when it is started until it reaches its maximum speed.
- Once the blast wheel has reached its rated speed the current drops to the no-load consumption (approx. 7 A).
- If the ammeter indicates more than the normal current value after 10 seconds, interrupt the power supply and find the cause.
- If the ammeter indicates a high load consumption after having reached the idle-running speed, the magnetic valve may be partially open or there may be another disturbance.
- Find out the cause of the disturbance and, if necessary, contact your **USF Blastrac/EBE** customer service engineer.
- Set the travel direction switch to "backward" (working direction). Select the speed using the drive speed control knob.

5

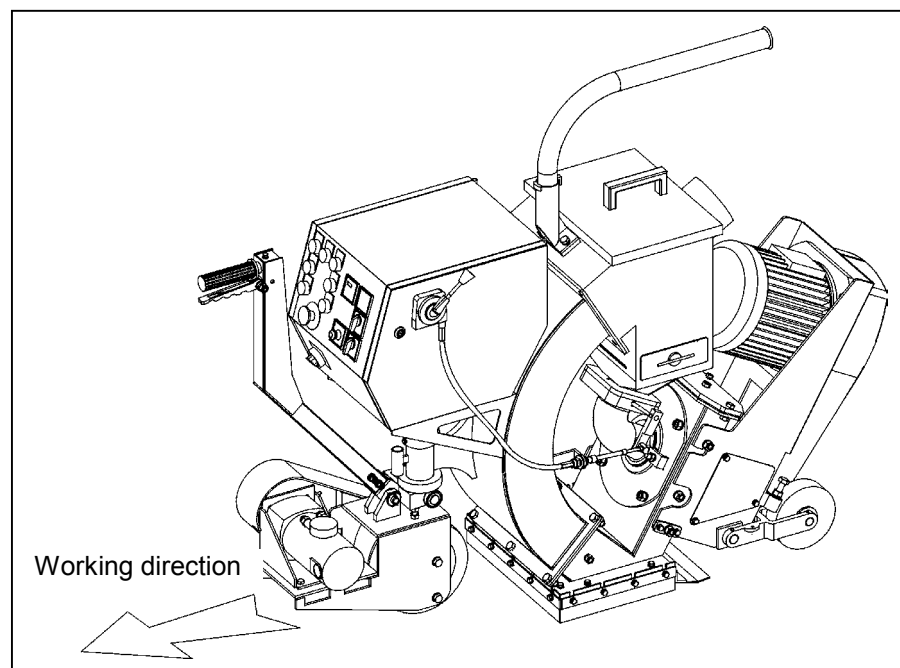

Fig. 5.4

Initial operation

- Actuate the dead man's handle in order to start the travel motor of the machine.

When blast cleaning concrete the abrasive magnetic valve may only be opened when the blast cleaning machine is travelling! If the machine is at a standstill and the valve is open deep holes may be blasted into the concrete surface within seconds.



- When the machine is travelling, pull the black abrasive control lever to operate the magnetic valve. Observe the ammeter. It may indicate the full load amperage (depending on the selected abrasive up to the operating current (20 A).
- An indication exceeding the full load value means overloading of the motor, whereas an indication below the full load value shows that there is not enough abrasive fed to the blast wheel. If necessary re-adjust the cable to the magnetic valve or refill the hopper with abrasive.
- After having blasted approx. 2 m close the abrasive valve, stop the machine and check the blasted surface.
- If the blast pattern is irregular it may be necessary to re-adjust the blast pattern (see Chapter 7.5 "Setting the blast pattern") or select another travel speed for the machine.

When the blast head is lifted from the floor, abrasive escapes from the sides of the blast head at high speed. If the machine is moved with the blast head raised, the abrasive magnetic valve must be closed.



Alter the travel direction only after having closed the magnetic valve.



The dust container of the filter unit must be emptied regularly. Comply with the local waste treatment regulations considering the removed material.



Contents Chapter 6

- 6.1 Operation
- 6.2 Information about advancing speed
- 6.3 Recommended blast paths
- 6.4 Switching-off the machine
- 6.5 What to do if a fault occurs
- 6.6 Safety shutdown
- 6.7 Restarting after a fault
- 6.8 Measures before and after long standstills



Operation

6.1 Operation

Normal start-up and operation of the blast machine 1-10DS is no different from the procedure described in Chapter 5 "Initial operation".

Carry out blasting in parallel tracks in such a way that the dust hose and electric cable do not become twisted.

Figure 6.1 shows the recommended blast paths leading away from the filter unit.

Make sure that no vehicles, such as forklift trucks and other equipment run over the electric cable and the dust hose.

The selection of the correct advancing speed of the blast machine is important for a good blast result. In the case that the surface has different characteristics (e.g. different hardness or different coating thicknesses), a uniform blast result can be achieved by varying the advancing speed during blast cleaning.

6.2 Information about advancing speed

The advancing speed depends on the material of the surface to be blast cleaned and the desired profiling.

The correct advancing speed can be found out by observing the blasted surface and varying the speed during the blast cleaning process.

Slight profiling on concrete requires a higher speed than coarse profiling (6 - 10).

Blasting on steel requires a very low advancing speed (0 -2).

Operation**6.3 Recommended blast paths**

Position the filter unit near to a power supply connection.

Place the blast cleaning machine near to the filter unit and spread out the hose as shown in fig. 6.1.

Work with the blast cleaning machine, with the hose spread out in the opposite direction, repeating the process away from the filter unit.

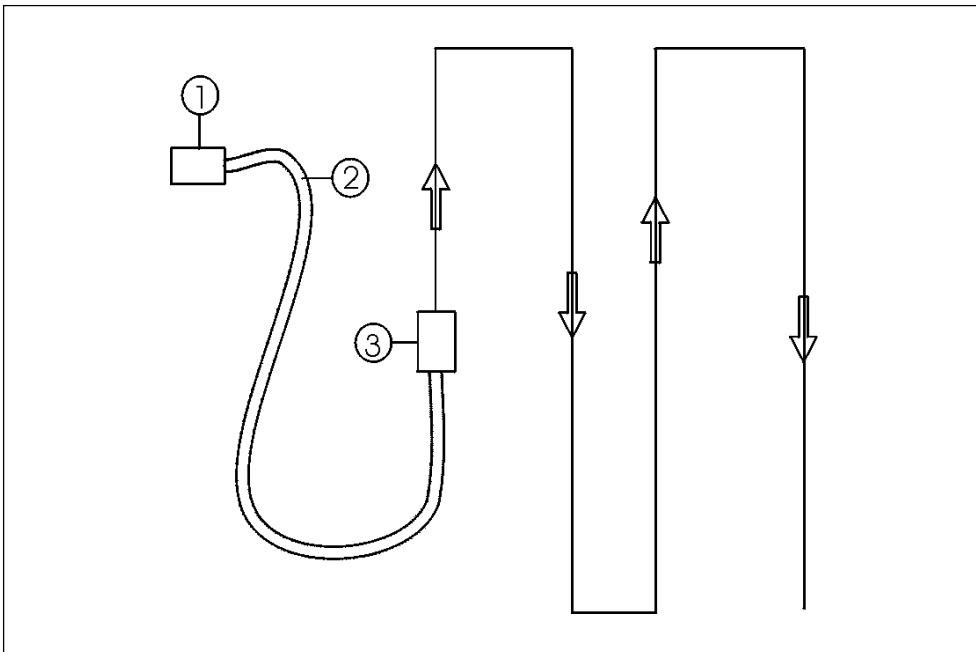

Fig. 6.1

- 1 Filter unit
- 2 Dust hose
- 3 Blast cleaning machine

Travel stepwise over the work area considering the service length of the dust hose.

Finish the blast cleaning process by blasting the area where the filter unit originally stood.

Operation**6.4 Switching-off the machine**

- Shut off the abrasive supply by actuating the abrasive control lever.
- Advance the machine until you are sure that no deep holes are being blasted into the surface.
- Release the dead man's handle for the travel motor so that it snaps back into its resting position. The travel motor switches off.
- Press the push button "Blast wheel OFF". This switches off the blast wheel motor.
- Press the push button "Control OFF" at the control box of the machine. This switches off the machine.
- Set the main switch of the blast cleaning machine to "Off".
- After several minutes press the push buttons "Fan OFF" and "Compressor OFF" on the filter unit.
- Set the main switch of the filter unit to "Off".

6



Make sure that all turning machine parts have come to standstill before any inspection or maintenance works are started.

When the **USF Blastrac/EBE** blast cleaning machine is put out of operation for a longer period of time, pull out the mains plug and cover the machine with a plastic foil.

6.5 What to do if a fault occurs

Irrespective of the following information, the local safety regulations are valid in any case for the operation of the machine.



First put the machine to its **Safety off position**. After that start looking for the defect.

6.6 Safety shutdown

The machine must be put to its safety off position before starting repair works. See Chapter 2 “Safety instructions”.



6.7 Restarting after a fault

See Chapter 5 “Initial operation”.

**6**

All persons in the proximity of the machine must wear safety glasses with lateral protection, ear protection as well as safety shoes. The operator is obliged to wear close-fitting protective clothing.



Operation**6.8 Measures before and after long standstills**

Standstill of the machine for a maximum of 3 months.

Before a long standstill period

Switch off the machine (see Chapter 6.4).

Protect the electric motors from moisture, heat, dust and shocks.

Clean the machine and cover it with a plastic foil.

Preserve bright parts of the machine and power pack with Tectyl 506, for example, or a similar preservative.

**After a long standstill period**

See Chapter 5 “Initial operation”.

Contents Chapter 7

- 7.1 Recommendations
- 7.2 Maintenance and inspection list
- 7.3 Repairing
- 7.4 The blast pattern
- 7.5 Setting the blast pattern
- 7.6 Setting the control cage
- 7.7 Setting the magnetic and brush seals
- 7.8 V-belts
- 7.9 Fitting the V-belts
- 7.10 Tensioning the V-belts
- 7.11 Taper locks
- 7.12 The chain drive
- 7.13 Fitting the chain wheels
- 7.14 Fitting the chain



Maintenance

Contents Chapter 7

7.15 Maintaining and repairing the chain

7.16 Adjusting the chain tension of the travel drive motor

7.17 Wear parts

7.18 Changing the tune-up kit

7.19 Changing the liners

7.1 Recommendations

With maintenance and inspection works, please observe Chapter 2 "**Safety instructions**".



Failures due to inadequate or incorrect maintenance may generate very **high repair costs** and long standstill periods of the machine. **Regular** maintenance is therefore imperative.

Operational safety and service life of the machine depend, among other things, on proper maintenance.

The following table shows recommendations about time, inspection and maintenance for the normal use of the machine.

The time indications are based on uninterrupted operation. When the indicated number of working hours is not achieved during the corresponding period, the period can be extended. However a full overhaul must be carried out at least once a year.

Due to different working conditions it cannot be foreseen how frequently inspections for wear checkings, inspection, maintenance and repair works ought to be carried out. Prepare a suitable inspection schedule considering your own working conditions.

Our specialists will be happy to assist you with more advice.



Prior to any repair works on the machine and its drives, secure the machine against unintentional switching-on. Put the machine to its safety off position.



The supplier's operating and maintenance instructions should also be followed during service and maintenance.



Maintenance

7.2 Maintenance and inspection list

Operating hours/ time period	Inspection points, maintenance instructions
12 h after repairing	Check the efficiency of all safety devices. Check all accessible screw connections for tight seat.
every 3 h	Check whether there is any foreign matter in the hopper, the feed spout or in the blast wheel unit.
daily and prior to starting work	<p>Verify the functioning of the fault current breaker.</p> <p>Check the hose connections for tightness and fixed seat.</p> <p>Check the hose to the filter for damages.</p> <p>Make sure that the dust container of the filter is emptied. Check blast wheel, feed spout, liners and fasteners for wear and damage.</p> <p>Check the separator parts for wear and defects. Remove foreign bodies and dust deposits.</p> <p>Check the level of abrasive in the storage hopper. Top up if necessary.</p> <p>Check the magnetic and brush seals for wear.</p> <p>Check the electric connections for sediments of dirt or foreign bodies.</p> <p>Check the electric motor for dirt and other contaminants.</p>
annually	Full overhaul and cleaning of the complete machine.

Maintenance

7.3 Repairing

As already mentioned in Chapter 5 “Initial operation” we recommend to execute the first repair works on the machine with the help of **USF Blastrac/EBE** personnel. With this your maintenance personnel gets the opportunity to be trained intensely.



Only those repair works are described which occur within the context of maintenance or which are required to replace wear parts.

If you replace parts yourself for specific reasons, the following instructions and work sequence have to be observed.

You should also stock all spare or wear parts that cannot be supplied quickly. As a rule, production standstill periods are more expensive than the cost for the corresponding spare part.

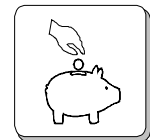

Screws that have been removed must be replaced with those of the same quality (strength, material) and design.

Prior to any repair works on the machine and its drives, secure the machine against unintentional switching-on. Pull out the mains plug in order to do this.



Maintenance

7.4 The blast pattern

Abrasive leaving the blast wheel blades is not thrown in all directions. Scatter is restricted to an angle of about 50°. This is achieved through the use of a control cage which surrounds the impeller. The position of the window in the control cage determines the blast pattern.

Correct adjustment of the control cage and thus of the blast pattern is the most important factor for optimum working with the 1-10DS blast cleaning machine.



Incorrect adjustment of the control cage results in very high wear and premature blasting-through of the liners in the blast wheel housing, as well as reduced blasting performance and a possible loss of the rebound energy of the abrasive.

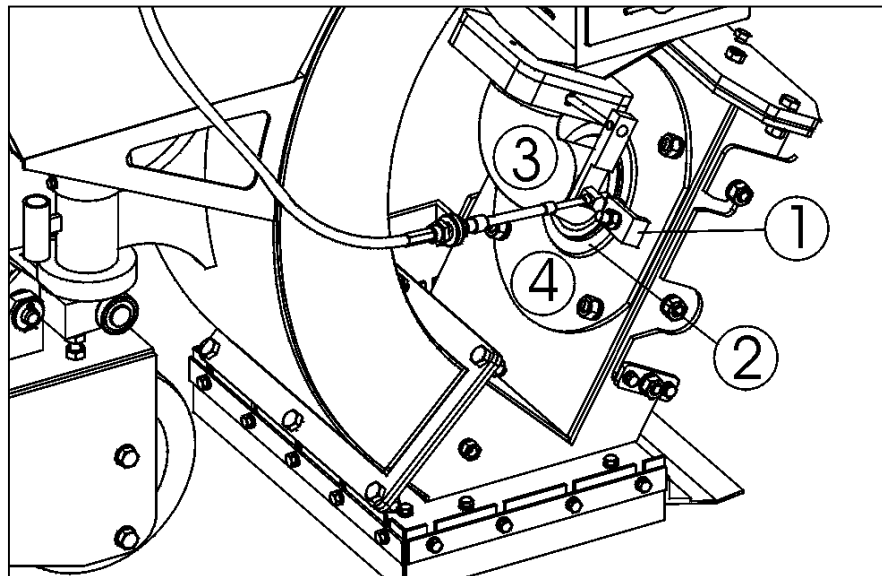

Fig. 7.1

- 1 Cage clamp
- 2 Control cage
- 3 Feed spout
- 4 Cage retaining plate

The adjustment is effected by loosening the cage clamps (pos.1) and turning of the control cage (pos.2).

Maintenance

Every time the control cage is replaced, the thread of the blast wheel fastening screw should be checked. Make sure that this screw will be tightened correctly. In addition, absolute care must be taken to clean the thread from dust and abrasive.



After each blast wheel repair work switch on the blast wheel motor for a short period (without feeding abrasive) in order to find out whether the rotating parts turn freely and without vibration. After that, the blast cleaning procedure can be continued.

The blast wheel motor is designed for a long service life. Damages to the blast wheel motor can be detected by unusual noises or functional failure of the electric motor. In this case notify our service department.



7.5 Setting the blast pattern

In order to obtain a uniform and perfect blast pattern on the surfaces to be treated, the correct adjustment of the blast pattern is of utmost importance.

Prior to any repair works on the machine and its drives, secure the machine against unintentional switching-on. Put the machine to its safety off position.



7

An incorrect adjustment of the blast pattern results in:

- Uneven cleaning (shadows on the right or left hand side).
- Extremely high wear of the tune-up kit and the liners.

Maintenance

The following 4 factors affect the blast pattern:

Turning direction of the blast wheel:

- The turning direction of the blast wheel must correspond to the instructions on the housing (arrow indicating the turning direction).

Worn tune-up kit:

- With increased wear of the tune-up kit (impeller, control cage) the blast pattern will change.

Size of abrasive:

- The size of the abrasive affects the blast pattern. With every exchange of abrasive, the blast pattern must be re-adjusted.

Position of the control cage:

- The correct adjustment of the control cage is the most important factor to obtain an optimum blast pattern. Each control cage has a lateral window. The position of the window determines where the abrasive is fed onto the blast wheel blades and where it hits the surface to be treated.
- After each exchange of the tune-up kit the adjustment of the control cage must be checked and re-adjusted by creating a blast pattern. The same applies for blasting on another type of surface.

7.6 Setting the control cage

The adjustment is effected by loosening the cage clamps and turning the control cage in the suitable direction. The cast grooves on the control cage show the position of the control cage opening. The feed spout remains in its former position. The following adjustment standard value is valid: the control cage opening is approximately opposite to the throwing angle. The abrasive grain size plays an important role here. Different types of abrasive have different throwing characteristics due to their different weights and frictional resistance. This means that you must never use different types of abrasive at the same time.

After fitting new spare parts always create a blast pattern in order to check the blasting direction. This is the only way to grant economical work and to avoid unnecessary wear and repair costs.

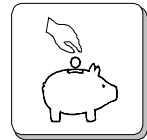

The adjustment can be carried out as follows:

- Determine the upper and lower window edges.
- Set the upper window edge (1) of the control cage to imaginary 11.30 of a dial (see fig. 7.2).

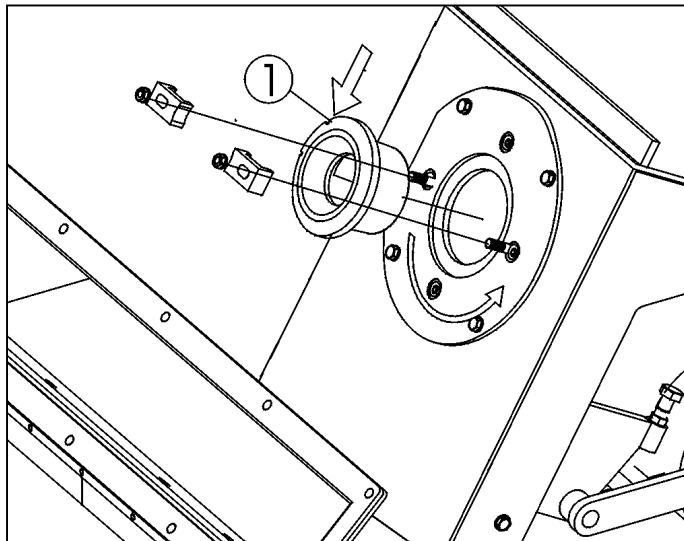

Fig. 7.2

Maintenance

- ❑ Move the blast head of the blast machine onto a 5-8 mm thick steel plate and blast for 45 seconds at full amperage without moving the machine from the spot.
- ❑ Move the machine from the blast zone and carefully inspect the steel plate.
- ❑ You will find the hot spot on the blasted surface where the machine has developed the highest blast cleaning intensity. This spot is normally somewhat lighter than the rest of the blast cleaned area due to the large amount of heat that is generated.

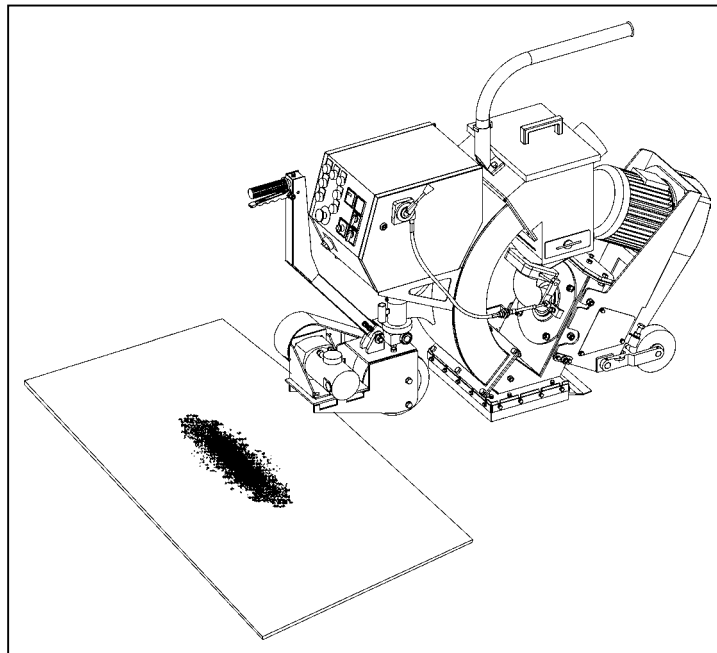

Fig. 7.3

- ❑ Adjust the control cage until the hot spot is exactly in the middle of the blast pattern.
- ❑ Now the blasting procedure can be started. When a concrete surface is to be blasted, check the blast pattern again after some meters and re-adjust slightly if necessary. The blast pattern will change with an increased wear of the tune-up kit and when the size of the employed abrasive is changed.

Maintenance

Never loosen the cage clamps or try to adjust the control cage when the machine is in operation.



- View from the middle of the blast machine toward the control cage:
- If the blast result shows strong blasting on the right-hand side and weak blasting on the left-hand side (shadows), turn the upper edge of the control cage clockwise for 3-6 mm.
- If the blast result shows strong blasting on the left-hand side and weak blasting on the right-hand side (shadows), turn the upper edge of the control cage anti-clockwise for 3-6 mm.

7.7 Setting the magnetic and brush seals

The adjustment height of the magnetic seals, parallel to the surface to be treated, should be set to about 8-10 mm everywhere.

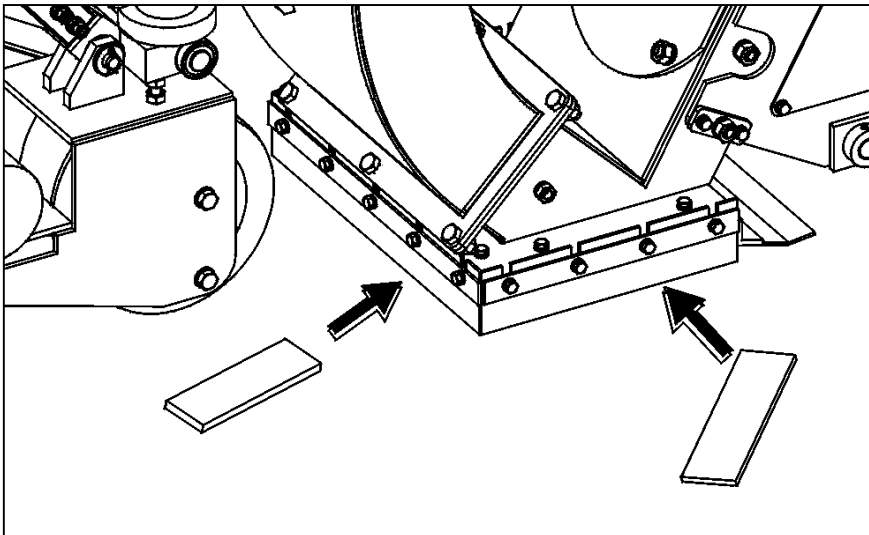

Fig. 7.4

For the height adjustment an 8 mm (stainless) steel strip is shifted below the magnetic sealing.

Maintenance

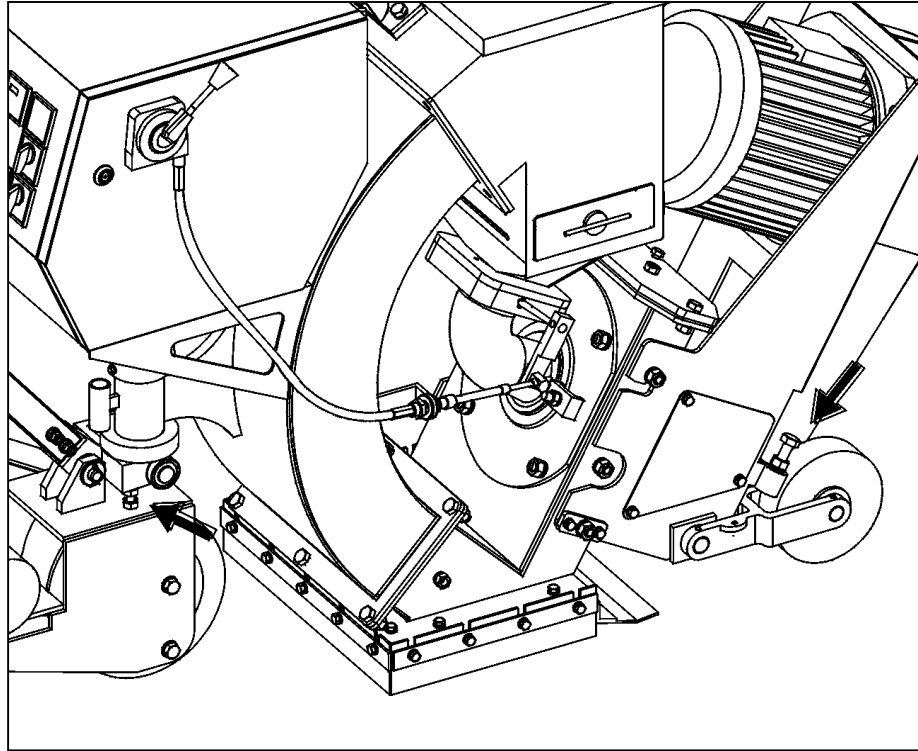

Fig. 7.5

Front setting screw	quantity:	2
Rear setting screw	quantity:	2

Adjust the height with the setting screws until the correct distance of 8-10 mm has been reached.

With the **USF Blastrac/EBE** model 1-10DS the adjustment is done using 4 setting screws (one each at the rear wheels and two at the front drive wheel bracket below the control box).

The height of the brush seals should be maximum 1 mm above the surface. Adjustment is effected through slotted holes.

7.8 V-belts

The V-belt drive is designed for the required drive power. Forcing the drive to grant a higher output by overtensioning the V-belt results in belt breaks, bearing damage and thus to lower efficiency. A low V-belt tension results in slippage causing an increased belt temperature and thus to premature destruction of the V-belts. Temperatures exceeding 70°C for a long period of time reduce the service life and performance of the V-belts. The grooves of the V-belt pulleys have to be free from rust, grease, dirt and damages. The use of belt wax or similar substances to increase the friction coefficient is unnecessary and damages the V-belts. Avoid any contaminations by oil, grease or chemicals.

In order to grant a perfect output transmission, the V-belt drive must be observed continuously.

V-belt ratings

See Chapter 10 “Spare parts”.

7.9 Fitting the V-belts

Remove the belt guard only when the blast wheel motor is at a standstill and the main switch of the blast cleaning machine is locked.



Release the tension of the V-belt drive by reducing the distance between the shafts of the blast wheel motor and blast wheel bearing unit.

Insert the V-belt in the V-belt pulley grooves manually without forcing the belt.

Maintenance

Tension the V-belt by increasing the distance between the shafts of the blast wheel motor and the blast wheel bearing unit as described below.

Mount the pertaining protective drive equipment.

7.10 Tensioning the V-belts

The correct V-belt pre-tension is of great importance for the perfect output transmission and for maintaining the normal service life of the V-belts. Insufficient or excessive pre-tensioning frequently leads to premature failure of the V-belts. Over-tensioning often causes bearing defects in the blast wheel motor or in the blast wheel bearing unit.

Check the correct pre-tension in accordance with fig. 7.6 by pressing down the belt. The distance the belt can be pressed down should be 8-13 mm.

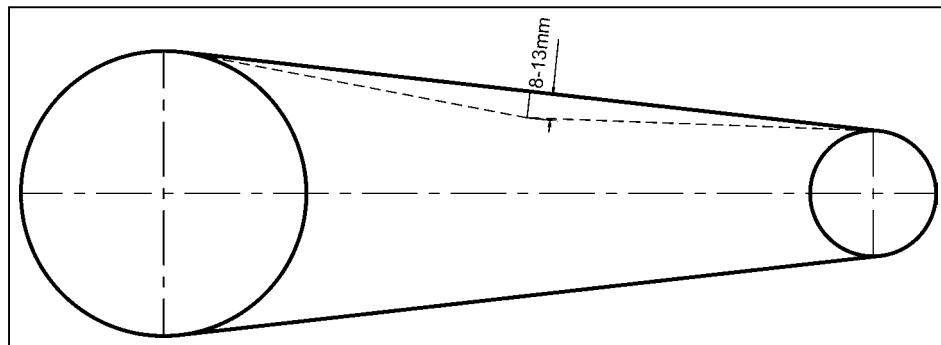

Fig. 7.6

7.11 Taper locks

Taper locks are used to shrink-fit hubs on shafts. Mounting and demounting only requires a screw driver DIN 911 (Allan key). Tightening and loosening is effected with the same threaded pins or screws.

Taper locks are cylindrical on the inside, tapered on the outside and slit longitudinally. The smaller bushes 2 and 3 have in the large face their cylindrical blind holes in parallel to the axis which, however, are only placed half in the bush material. The other halves of these blind holes are threaded and are placed inside the hub.

Threaded pins or screws are screwed to the stop in the boreholes using an Allan key. When the screws are tightened further using a certain amount of force the hub is drawn up to the tapered bush which is pressed onto the shaft with great force.

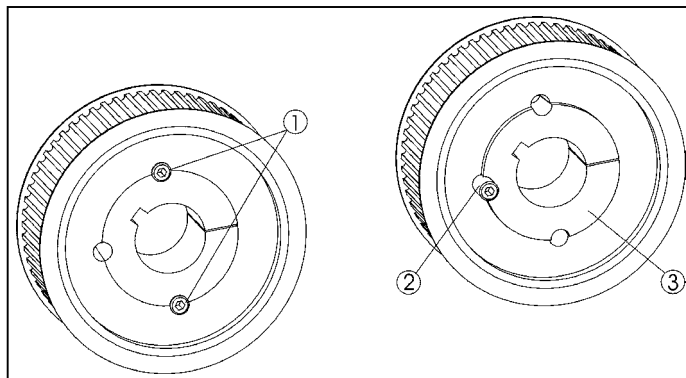

Fig. 7.7

Demounting

- Demount the screws (1) in the belt pulleys. Lubricate the thread and the tip of the screw and turn it into the bore (2) as shown in fig. 7.7.
- Turn the screw until the taper lock (3) is loosely seated inside the pulley and, thus, the assembly is loose on the shaft.
- Take the pulley and the taper lock from the shaft.

Maintenance

Mounting

- Make sure that all contact surfaces are free from dirt and oil. Place the taper lock into the pulley.
- Lubricate the screws slightly and insert them into the respecting threaded holes (1).
- Clean the shaft and shift the pulley with the taper lock, as one unit, onto the shaft and position the assembly. Take care that first the taper lock is fixed on the shaft before the pulley is received by the bush.
- Use an Allan key to alternately screw in the screws.
- Knock the frontal face of the bush lightly with a hammer to make sure that the bush is seated in the centre of the pulley (use a mandrel to avoid any damages).
- Now tighten the screws. Repeat the alternating hammering and tightening until all screws have been fully tightened.

7.12 The chain drive

The mounting, demounting and repair works should always be executed with the appropriate tools. With these works the prevailing safety regulations must be strictly observed.

Chain drives are relatively robust and reliable even under unfavourable operating conditions. Incorrect mounting and insufficient lubrication and maintenance cause premature wear of the chain and the chain wheels. Careful fitting of the chain drives and appropriate maintenance therefore both contribute to a long service life.

Remove the chain guard only when the drive motor is at a standstill and the main switch of the blast cleaning machine



7.13 Fitting the chain wheels

The chain wheels must be aligned. In order to achieve this the both the shafts and the chain wheels must be parallel and dimensioned according the load.

Check the mounting precision by means of a ruler to be put to the chain wheels (see fig. 7.8). This has to be carried out several times with different chain wheel positions. Incorrect mounting makes the internal link plates press against the external link plates and, thus, accelerates the chain wear or even causes the chain wheels to lock up.

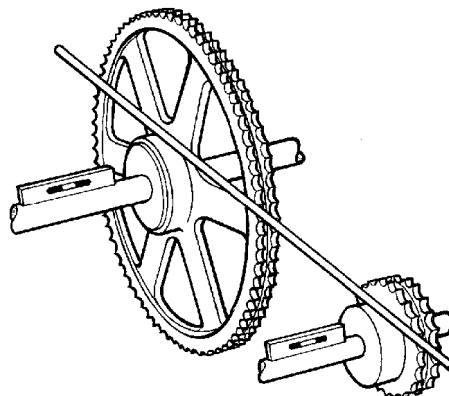

Fig. 7.8

Maintenance

7.14 Fitting the chain

Before mounting the chain it must be degreased to prevent any abrasive or abrasive particles from adhering.

The chain is supplied as a chain string and has to be prepared during mounting. This is done as follows: Place the chain on the chain wheels so that the links lie in tow adjacent gaps between the teeth. Now close the chain using the coupling link. With heavy chains or big distances between the shafts use a pre-stressing tool in order to bring the two end links so close together that the coupling link can be inserted without being deformed (fig. 7.9).

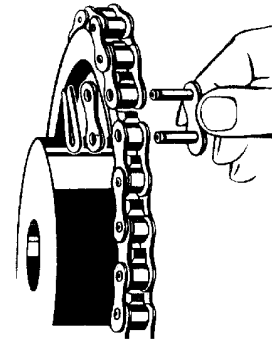

Fig. 7.9

On mounting coupling links with springs, their closed sides should point to the running direction of the chain (see fig. 7.10). Put the spring onto the link plate and press it over the pin into the ring groove by means of a pair of tongs. Demount the spring in the opposite order.

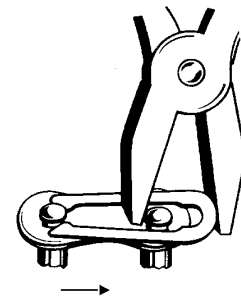

Fig. 7.10

7.15 Maintaining and repairing the chain

A chain drive needs relatively little maintenance when the correct chain is selected, when it is mounted correctly and, in this case of application, is not lubricated. The drive chain is protected by a chain guard. The chain guard prevents excessive contamination and prevents accidents.

The chain drive should be cleaned every three months. On these occasions check the aligning of the chain wheels and the chain tension.

Maintenance

In order to clean thoroughly first remove the dirt adhering to the outside of the chain drive using a hard or wire brush. Then wash the chain in petroleum ether or similar. After that clean the dirt from the internal parts of the chain. For this put the chain for approx. 24 hours in petroleum ether, diesel or another solvent in order to soften the dirt in the chain joints and the hardened lubricant remnants. Move the chain several times back and forward in the bath to clean the joints.

7.16 Adjusting the chain tension of the travel drive motor

The travel drive motor is mounted on a receiver plate with slotted holes. When it is necessary to re-tense the chain, this can be carried out by shifting the motor in the slotted holes. The correct chain tension is achieved when the chain allows to be pressed for about 5 mm between the chain wheels (fig. 7.11).

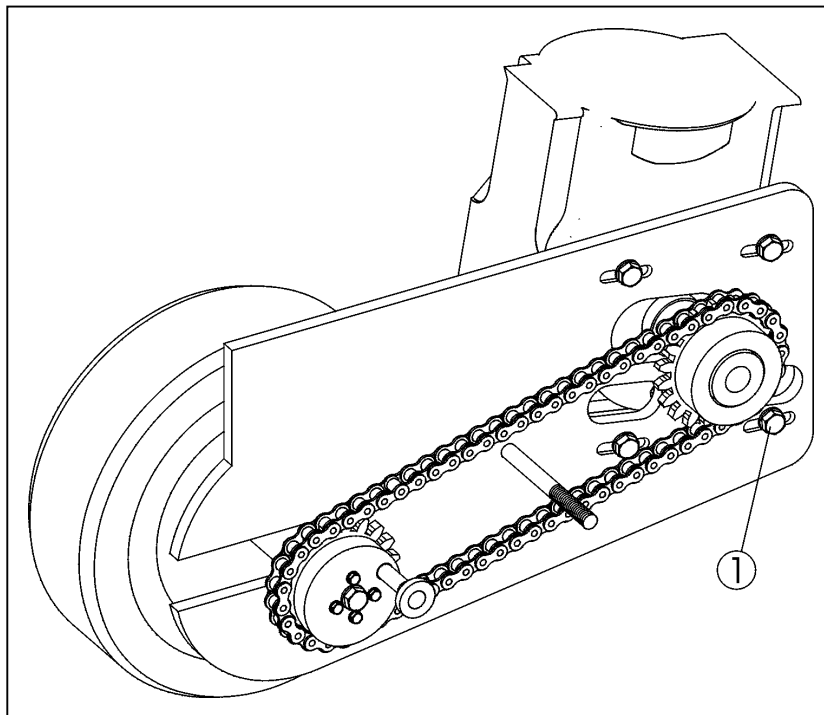

Fig. 7.11

Maintenance

7.17 Wear parts

The tune-up kit

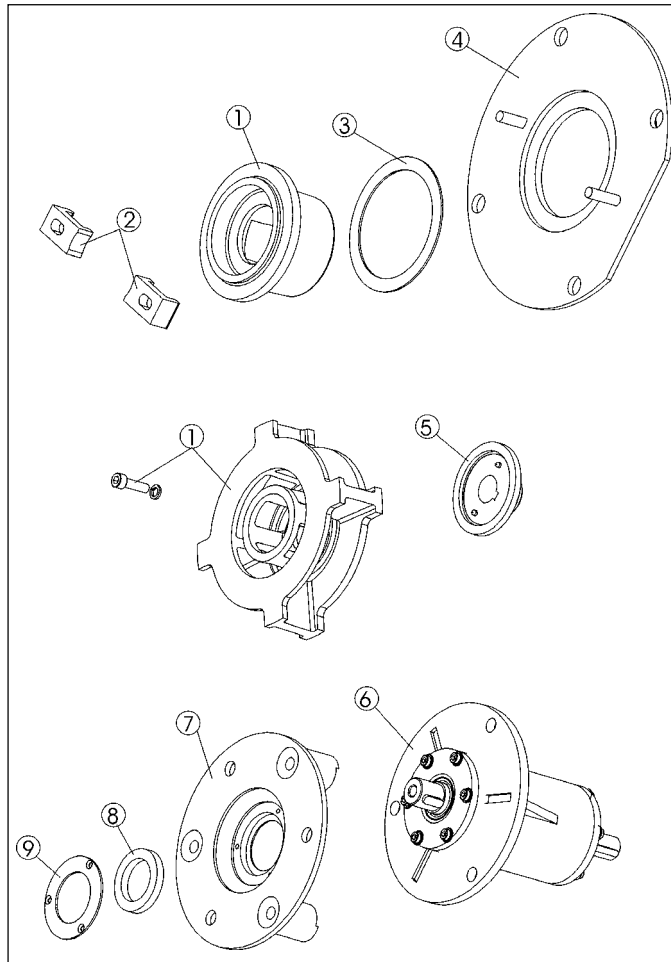

Fig. 7.12

- 1 Tune-up kit
- 2 Control cage clamp
- 3 Control cage shim
- 4 Blast wheel cover plate
- 5 Wheel hub
- 6 Bearing unit
- 7 Bearing unit flange
- 8 Felt seal
- 9 Felt seal cover

The liners

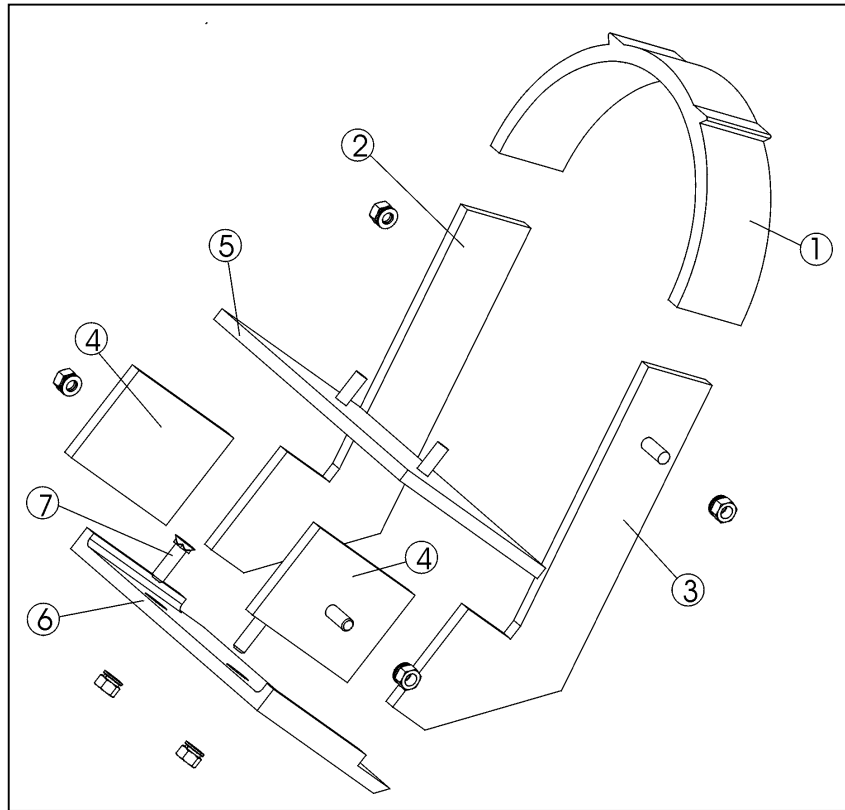

Fig. 7.13

- 1 Top liner
- 2 Left liner
- 3 Right liner
- 4 Plenum side liner
- 5 Plenum top liner
- 6 Plenum bottom liner
- 7 Fixing screw for liner



Maintenance

7.18 Changing the tune-up kit

The tune-up kit consists of the blast wheel, control cage and fixing screw.

Demounting:

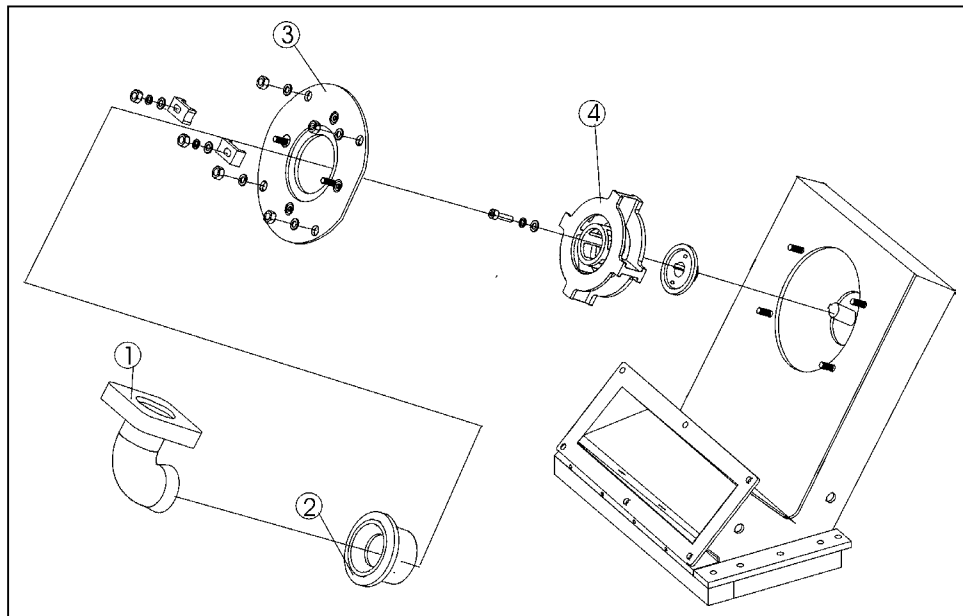

Fig. 7.14

- 1 Remove the feed spout (1) by loosening the star nuts and pulling the feed spout out of the housing.
- 2 Loosen the cage clamps and remove the control cage (2).
- 3 Unscrew the 4 screws of the blast wheel cover plate (3) and take it off.
- 4 Loosen the fixing screw of the blast wheel (4) while holding the blast wheel still. Take the blast wheel out of the housing.
- 5 Check the wheel hubs for wear and replace them if necessary.

Maintenance**Mounting:**

Fig. 7.15

- 1 Clean all threads and use a new blast wheel fixing screw. Place the blast wheel (1) on the wheel hub through the blast housing opening. Tighten the blast wheel by fastening the fixing screw.
- 2 Fix the blast wheel cover plate (2) using the 4 screws.
- 3 Insert the control cage (3) in the centre (observe Chapter 7.5 "Setting the blast pattern") and clamp the control cage with the cage clamps so that the blast wheel can rotate freely. Turn the blast wheel manually. It must rotate freely.
- 4 Place the feed spout (4) in the housing and fix it with the star nuts onto the separator at the bottom of the magnetic valve.

Maintenance

7.19 Changing the liners

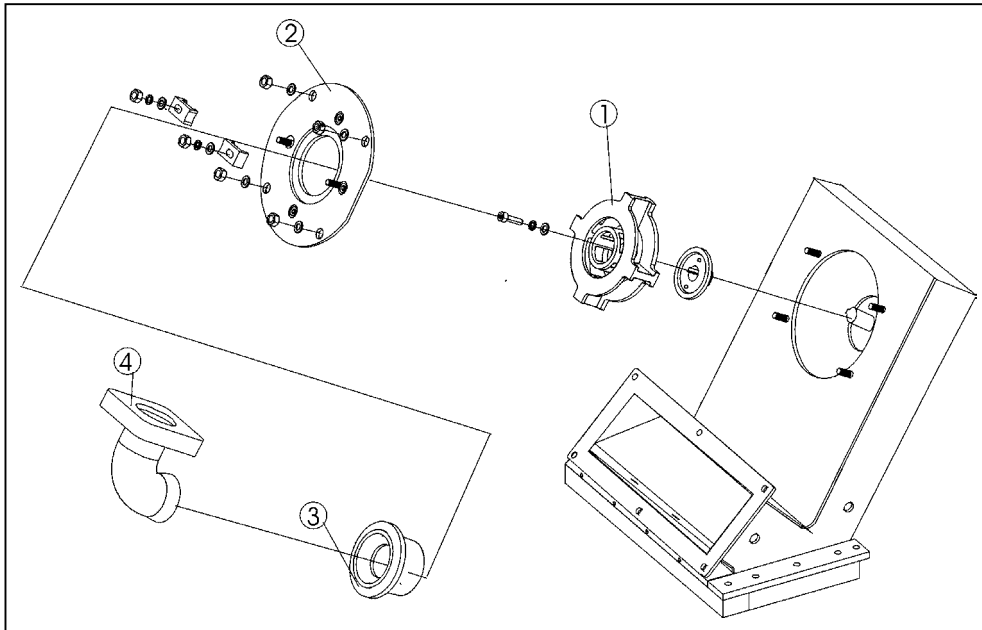
Demounting:

- 1 Loosen the pressure screws of the top liner. Unscrew the screws of the blast housing cover and remove it.
- 2 Loosen the fastening screws for the left and right liners, turn the liners towards the inside of the blast housing and take them out at the bottom of the housing.
- 3 When the side liners have been removed from the housing, turn the top liner towards the housing opening and remove it.

For demounting the plenum liners, loosen the fixing screws at the outside of the rebound area and push the liners to the inside and remove them at the bottom.

For demounting the top and bottom plenum liners loosen the fixing screws and take them out at the bottom of the housing.

Mounting:

Prior to mounting the liners, check all threads for contaminants and clean them if necessary.

- 1 First place the plenum liners inside the housing and fix them with nuts.
- 2 Place the side liners inside the housing in a way that the bolt of the liner aligns with the hole in the housing. Fasten the side liners with nuts.
- 3 Mount the top liner. Make sure that the top liner sits close at the edges of the side liners. For this, tighten the pressure screws of the top liner **slightly** and press the top liner against the side liners.



Contents Chapter 8

8.1 Recommendations for the electrical systems

8.2 Circuit diagrams 1-10DS

Electrical systems**8.1 Recommendations for the electrical systems**

Work on **electrical** equipment or operating materials may only be undertaken by a **skilled electrician** or by **trained** persons under the **guidance** and **supervision** of a **skilled electrician** as well as in accordance with the **electrical engineering regulations**.



Order electric components referring to the circuit diagrams in Chapter 8.2 or contact **USF Blastrac/EBE** Customer Service.



Observe the regulations of EN60204-1 and VDE0701 (measurements after maintenance and repairs).

Electrical systems

8.2 Circuit diagrams 1-10DS

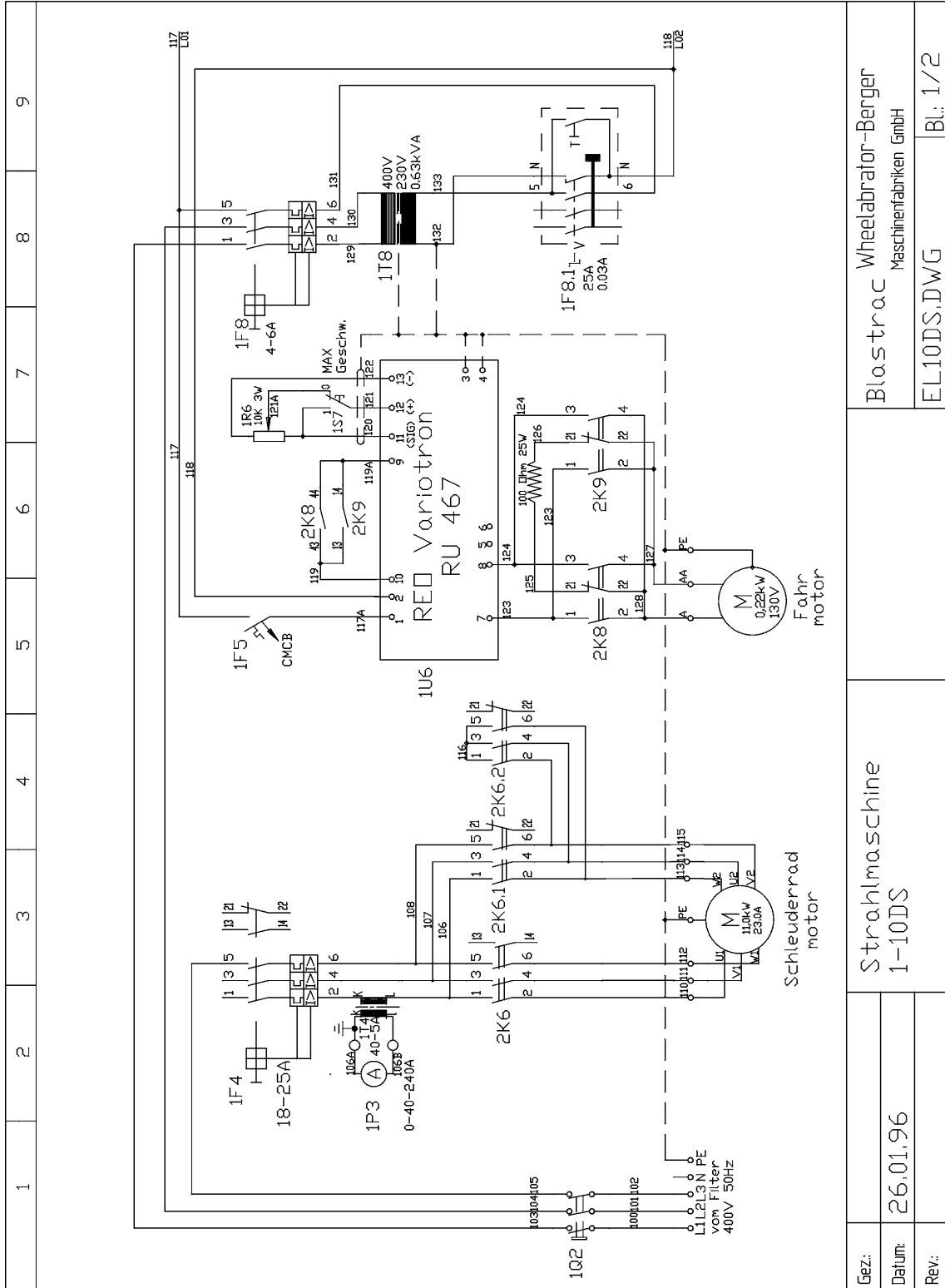

Gez.:	Strahlmaschine 1-10DS	Wheelabrator-Berger Maschinenfabriken GmbH
Datum:	26.01.96	EL10DS.DWG
REV.:		Bl: 1/2



Electrical systems

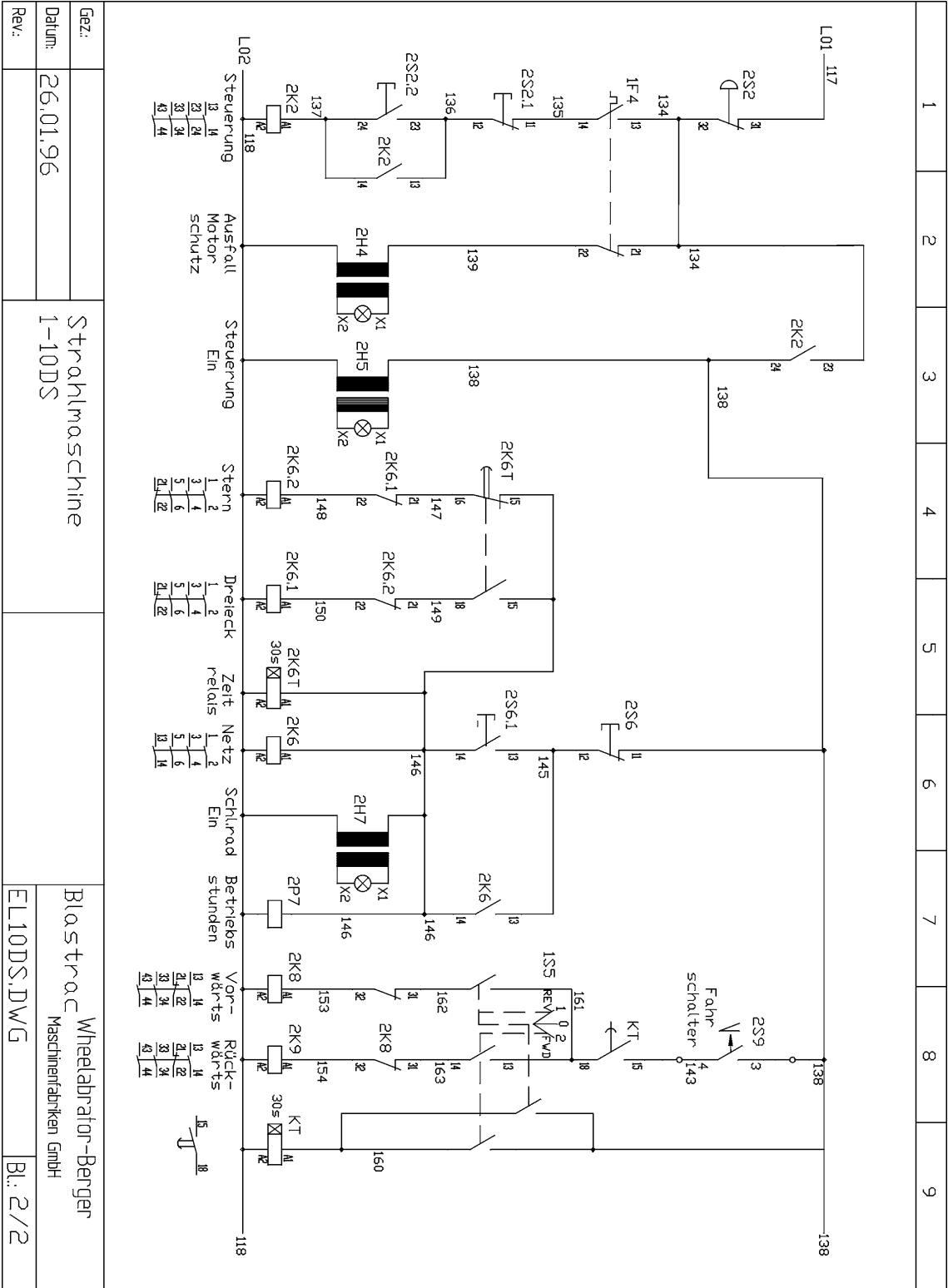

Gez.:
Datum: 26.01.96
Rev:

Strahlmaschine
1-10DS

EL10DS.DWG
Bl. 2/2



Contents Chapter 9

9.1 Fault diagnosis - blast machine

9.2 Fault diagnosis - electrical system

Fault diagnosis

9.1 Fault diagnosis - blast machine



Prior to any repair works on the machine or its drives the machine must be secured against unintentional switching-on. Put the machine to its Safety off position.

Fault	Possible cause	Remedy
Excessive vibration	Blast wheel is worn irregularly. Imbalance due to worn or broken wheel blades.	Replacing the tune-up kit. Replace the tune-up kit and remove all broken parts from the machine.
Unusual noise	Too little play or poor alignment of the rotating parts.	Check alignment of the rotating parts (blast wheel and control cage).
	Loose and incorrect set screws.	Check whether all screws and parts are fixed tightly).
	Squeaking wheels.	Replace the wheels.
	Seizing motor.	Replace the motor.
Reduced or no blasting performance	Inadequate abrasive supply to the blast wheel.	Clean wire mesh, top up abrasive if necessary.
	Contaminated abrasive.	Abrasive is heavily contaminated, check the ventilation system.
	Feeding of abrasive - magnetic valve and abrasive storage hopper.	Check and clean blocked feed spout or magnetic valve.

Fault diagnosis

Fault	Possible cause	Remedy
Reduced or no blasting performance	Blast wheel or control cage.	Worn blast wheel or control cage, replace tune-up kit if necessary.
	Adjustment of the magnetic valve.	Check the adjustment of the magnetic valve.
	"Shocked blast wheel". At the start of the blast process too much abrasive at once hits the wheel.	Close the magnetic valve and stop the blast wheel motor. Start the blast process again and slowly open the valve.
	The travel speed is too high.	Reduce the travel speed.
Escaping abrasive	Poor sealing.	Check all seals and replace if necessary.
Abrasive loss on the surface or escaping abrasive at the blast head	Incorrect height adjustment of the magnetic seals.	Adjust the magnetic seals.
	Worn magnetic seals.	Replace the magnetic seals.
	Poor abrasive quality.	Contact USF Blastrac/EBE .
Contaminated abrasive	Worn tune-up kit.	Replace the tune-up kit.
Contaminated abrasive	The filter unit is not generating enough suction power so that dust remains in the abrasive.	Check the filter unit (cartridges and seals)

Fault diagnosis

Fault	Possible cause	Remedy
Excessive wear in blast housing and rebound plenum	Wrong abrasive. Incorrect setting of the control cage	Contact USF Blastrac/EBE . The thrown abrasive blasts the housing and not the surface to be blasted. Adjust the blast pattern.
Machine is not moving	The travel speed is too low. Blast head gets caught on the floor.	Increase the travel speed. Press down the steering lever for a short time.

9.2 Fault diagnosis - electrical system



Prior to any repair works on the machine or its drives the machine must be secured against unintentional switching-on. Put the machine to its Safety off position.

Fault	Possible cause	Remedy
Control system does not switch on	Motor protection switch has triggered.	Check and switch on again. Check the mains power supply.
Control lamp for motor protection lights up	Motor protection switch has triggered. Excess current caused by a defective unit (motor etc.).	Switch on the motor protection switch again. Have the fault checked by an electrician.

Fault diagnosis

Fault	Possible cause	Remedy
Control system switches off during operation	Filter unit safety fuse or fault current breaker has triggered.	Have the fault checked by an electrician.
	Connection cable is defective.	Replace the cable.
	Cables connecting the units (travel motor, etc.) are defective.	Replace the cable.
	Motor protection switch has triggered.	Have the fault checked by an electrician.
Machine does not travel	Main switch of the filter unit switches off due to overload.	Main switch "OFF", with fault call an electrician.
	Fuse defective, short circuit in the travel motor lead or tachometer lead, motor defective.	Have the unit checked by an electrician.
	Control unit defective.	Replace the control unit.
	Potentiometer defective.	Replace the potentiometer.

Note: If the motor protection switch of the blast wheel motor has been triggered by overload, it can be switched on again after a short cooling down period.

1-10DS

Operating Instructions 

Spare parts

Contents Chapter 10

10.1 Spare parts 1-10DS

Spare parts

10.1 Spare parts 1-10DS

Blast wheel unit

Item	Part no.	Description	Qty.
	B21620	Bearing unit with flange (Items 1-4)	
1	B21629	Bearing unit	1
2	B21624	Bearing unit flange	1
3	B20295	Felt seal	1
4	B21625	Felt seal cover	1
5	B21075	Distance ring for tune-up kit (set of 2)	5
6	B20397	Wheel hub	1
7	979644	Blastwheel cover plate	1
8	972781	Control cage shim	1
9	969803	Control cage clamp	2
10	B20536K	Tune-up kit	1

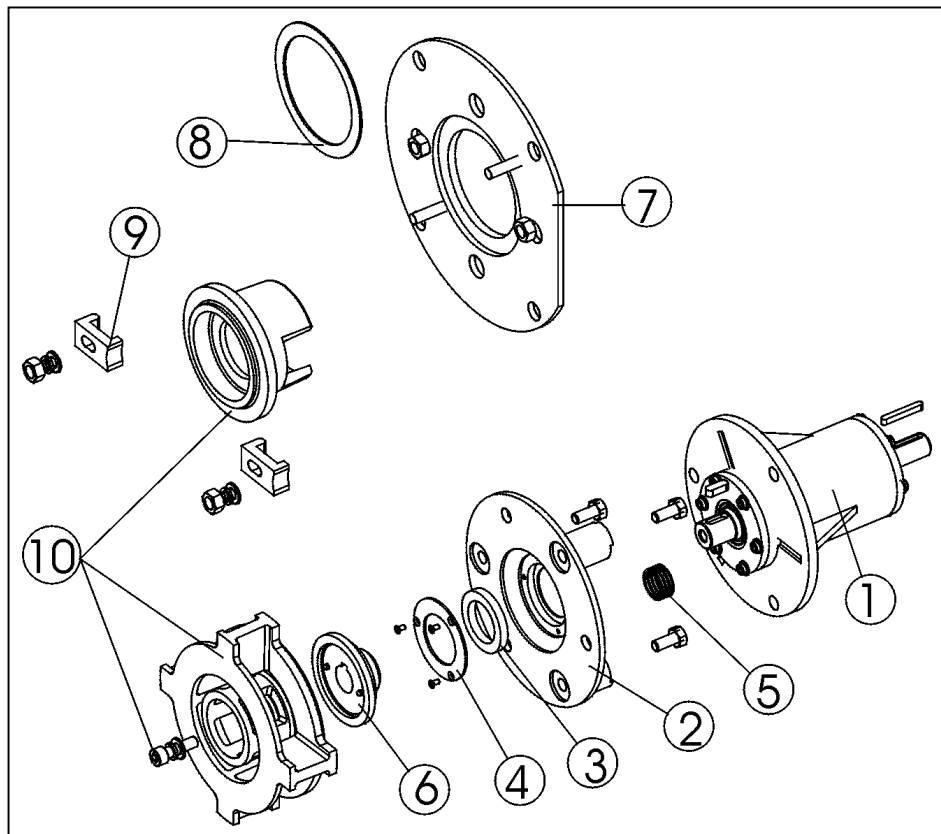

Fig. 10.1

Spare parts

Liners

Item	Part no.	Description	Qty.
1	B20325	Top liner	1
2	B20398	Left liner	1
3	B20399	Right liner	1
4	972275	Plenum side liner	2
5	490044	Plenum top liner	1
6	969572	Plenum bottom liner	1
7	969579	Liner screw M10x35	2

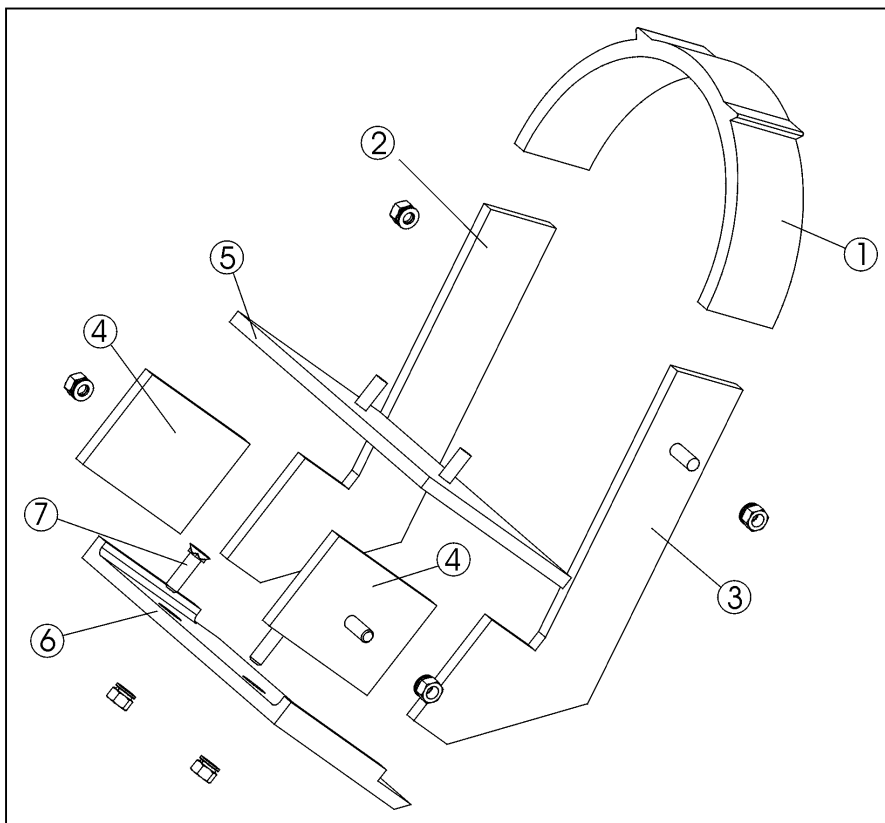

Fig. 10.2

Spare parts
Travel drive

Item	Part no.	Description	Qty.
1	980160	Drive wheel bracket	1
2	970198	Lifting fork	1
3	980010	Steering lever	1
4	970132	Drive motor bracket	1
5	009320	Geared motor	1
6	980114	Traction wheel yokeshaft	1
7	490079	Drive wheel	1
8	975346	Drive shaft	1
9	205571	Bearing	2
10	477629	Drive wheel hub	1
11	477630	Sprocket retainer	1
12	477631	Idler sprocket	1
13	971043	Sprocket	1
14	004256	Drive chain	0,94m
15	001264	Chain link	1
16	478198	Quick release pin	1
17	970133	Chain guard	1
18	970134	Chain guard cover	1
19	970095	Limit switch cover	1
20	454796	Limit switch	1
21	970196	Trip lever	1
22	453290	Handle grip	1
23	970247	Bracket pin	1
24	B20316	Bearing shaft	2
25	B20327	Bearing	2
26	2621-671	Sleeve-bearing bush	1

Spare parts

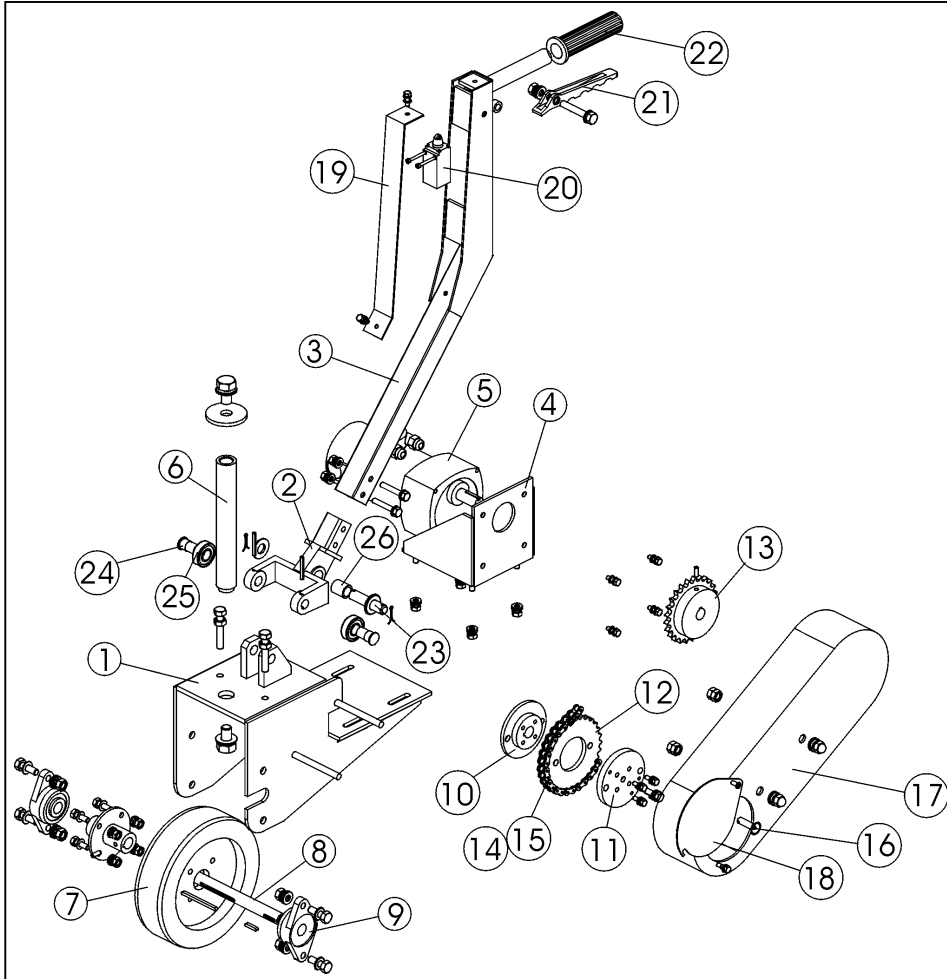

Fig. 10.3

Spare parts

Separator

Item	Part no.	Description	Qty.
1	B20537	Separator 1-10DS	1
2	980012	Deflector	1
3	970117	Separator tray	1
4	970452	Separator tray lock	1
5	970385	Separator handle	1
6	980011	Separator cover	1
7	B20425	Cable guide	1
8	B20426	Cable guide support	1

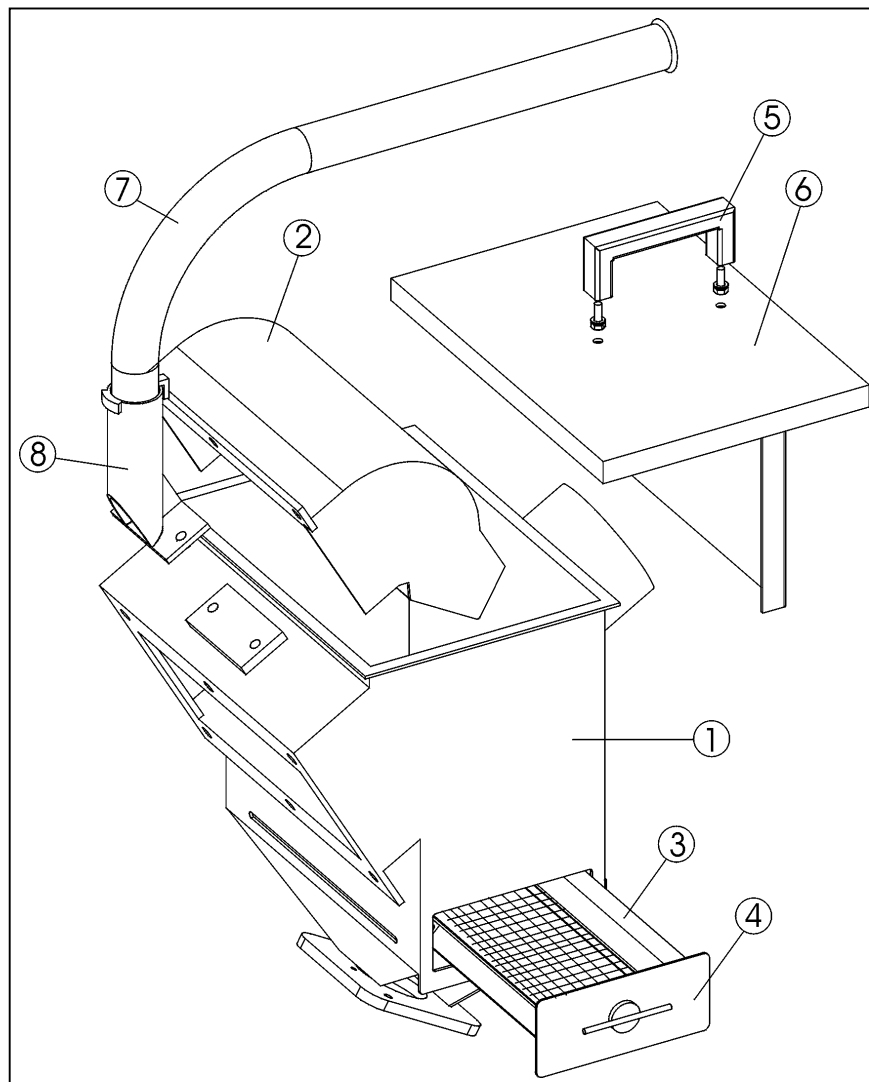

Fig. 10.4

Spare parts

Blast housing

Item	Part no.	Description	Qty.
1	975357	Blast housing 1-10DS	1
2	979644	Blastwheel cover plate	1
3	969803	Control cage clamp	2
4	B20453	Blast housing cover seal	1
5	B20433	Blast housing cover	1

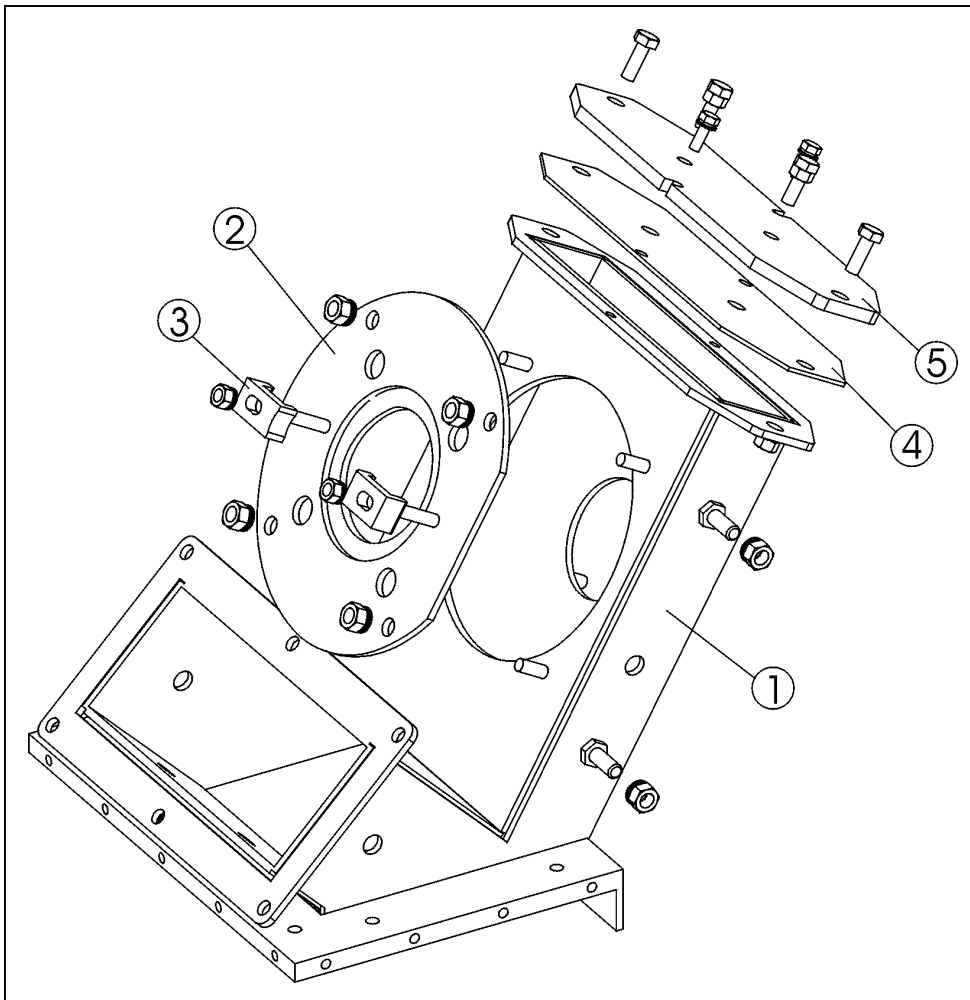

Fig. 10.5

Spare parts

Magnetic valve unit

Item	Part no.	Description	Qty.
1	B20443	Feed spout	1
2	B20444	Magnetic valve assembly	1
3	B20446	Valve lever	1
4	B20519	Abrasive control lever	1
5	B20520	Abrasive control cable	1
6	B20521	Pivot for abrasive control cable	1

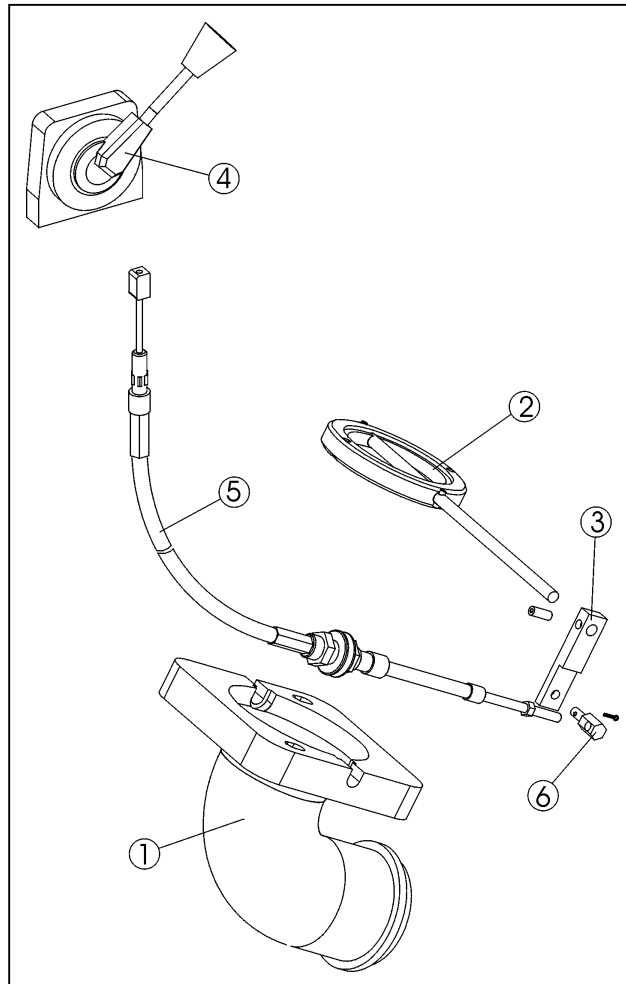

Fig. 10.6

Spare parts

Blast head

Item	Part no.	Description	Qty.
1	970030	Front magnet	1
2	490047	Side magnet	2
3	B20410	Front brush	1
4	B20411	Side brush right	1
5	B20423	Side brush left	1
6	679674	Skid seal	1

alternative for brush sealing:

7	970190	Base seal	1
8	970046	Seal retainer (front)	1
9	970045	Seal retainer (side)	2

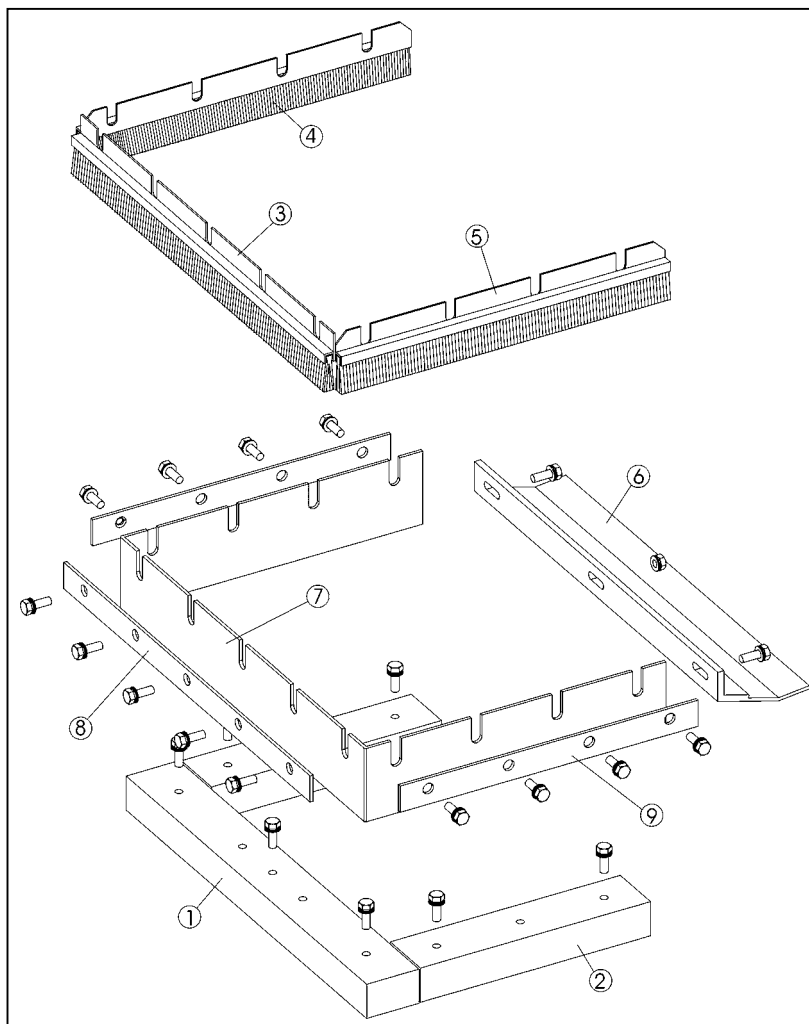

Fig. 10.7

Spare parts

Blast wheel drive

Item	Part no.	Description	Qty.
1	970168	Belt guard	1
2	491523	Top pulley with taperlock	1
3	009321	Bottom pulley with taperlock	1
4	491522	Belt	1
5	980008	Motor bracket	1
6	970116	Cover plate	2
7	970171	Keep plate	2
8	970489	Blast wheel motor	1
9	B21629	Bearing unit	1
10	970199	Idler wheel bracket	2
11	970258	Idler axle pin	2
12	001228	Idler wheel	2
13	970256	Idler pivot pin	2

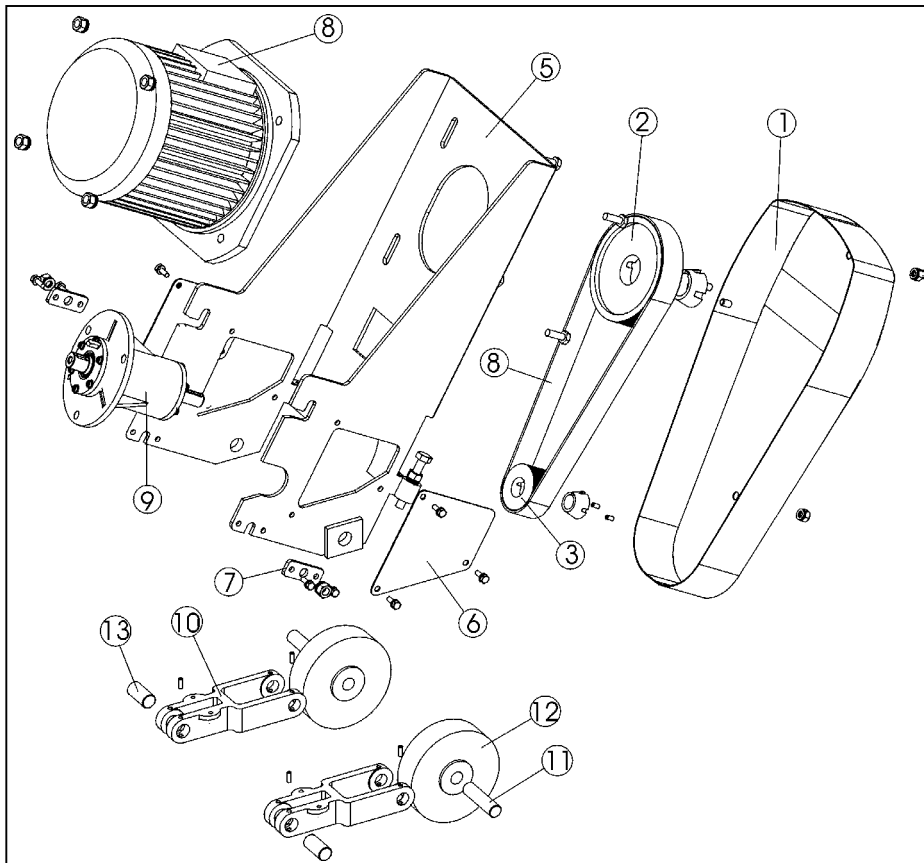

Fig. 10.8

Spare parts

Rebound plenum

Item	Part no.	Description	Qty.
1	980009	Rebound plenum 1-10DS	1
2	B20319	Shaft cover	1
3	2621-229	Sleeve-bearing bush	2
4	B20315	Lifting plate	1
5	B20318	Seal retainer	1
6	960855-2	Felt seal	1
7	456550	Shock absorber	4

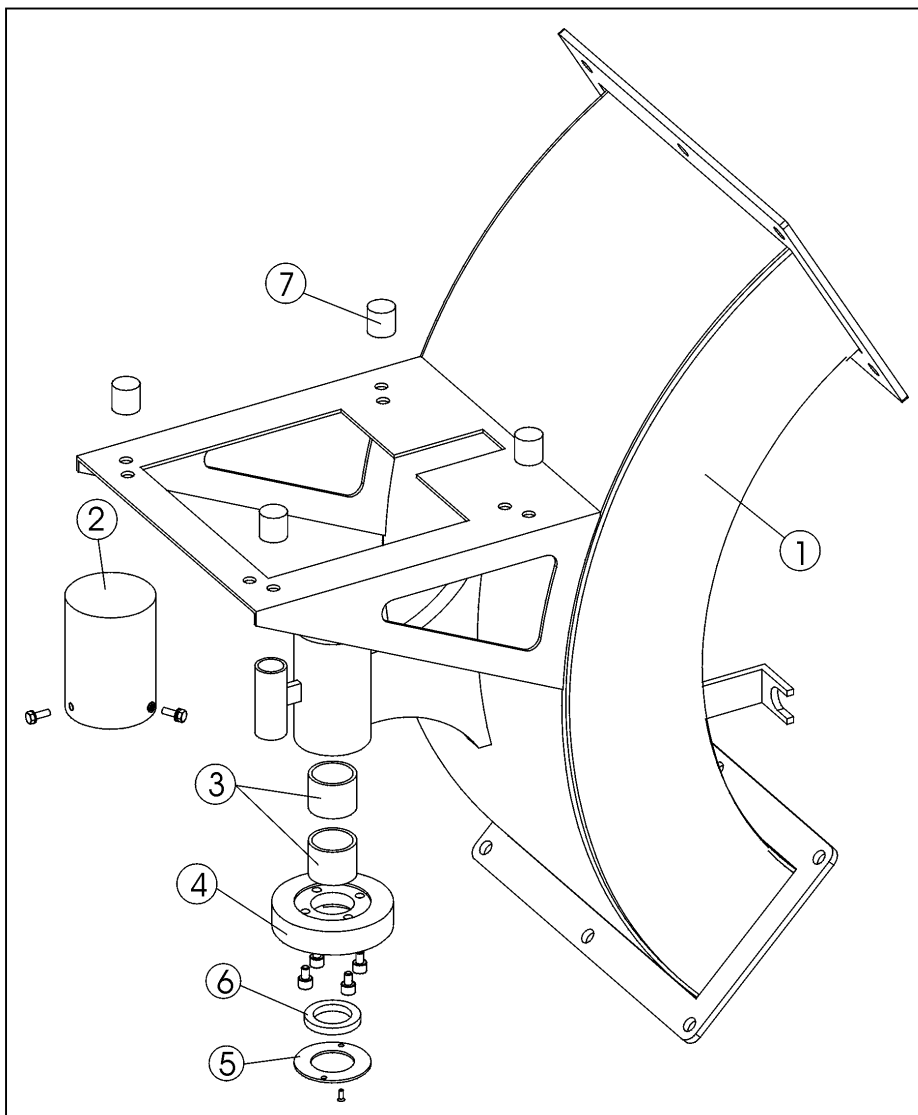

Fig. 10.9

Spare parts
Maintenance box 1-10DS

	Maintenance box 1-10DS complete	000115
1	Metal box	001022
1	Left liner	B20398
1	Right liner	B20399
1	Top liner	B20325
3	Tune-up kit	B20536
1	Abrasive control cable	B20520
1	Rear seal	679674
2	Side brush left	B20423
2	Side brush right	B20411
2	Front brush	B20410
3	Belt	491522
1	Open-end spanner 10/11	001017
1	Open-end spanner 13/15	001018
1	Open-end spanner 17/19	001019
1	Open-end spanner 24/26	001042
1	Allenkey 3	001033
1	Allenkey 6	001016
1	Hammer	000151
1	Ratchet spanner ½"	000144
1	Box spanner SW 8 mm	000150
1	Box spanner SW 13mm	000146
1	Box spanner SW 17mm	000147
1	Box spanner SW 19mm	000148
1	Screwdriver 6 x 25	001037
1	Screwdriver 5,5 x 100	001032
1	Insulated screwdriver	001035
1	Water pump pliers	001056
1	Safety glasses	001031