

Operating Instructions

Stud welding unit LBS 44 / LBS 75 / LBS 80

Contact stud welding gun PKM-1B

Gap stud welding gun PHM-1A

Special stud welding gun PIM-1B

BTH Tech GmbH

Ohmstraße 3
D-85221 Dachau

Telephone: +49 (0)8131 5159-0

Fax: +49 (0)8131 5159-11

info@bth-tech.de

www.bth-tech.de

Contents

1	Introduction	4
1.1	General information.....	4
1.1.1	For your safety	4
1.1.2	Field of application of the stud welding system	4
1.1.3	Characteristics of the stud welding system	4
1.2	Components of the stud welding system.....	5
1.3	Functional principle of the stud welding system	5
1.4	Contact stud welding gun PKM-1B	6
1.5	Gap stud welding gun PHM-1A	7
1.6	Special stud welding gun PIM-1B	8
1.7	Meaning and functional description of the symbols	11
1.8	Other descriptions.....	12
1.9	Welding elements (welding studs)	12
1.10	Material combinations	13
1.11	Welding on centre punches or scribed lines.....	13
2	Work safety and rights.....	14
2.1	Safety symbols.....	14
2.2	Safety instructions.....	14
2.3	Proper use	17
2.4	Guarantee and liability.....	18
2.5	Copyright	18
3	Installation.....	19
3.1	Receiving inspection	19
3.2	Storage	19
3.3	Transport	19
3.4	Place of use	19
3.5	Positioning the unit.....	19
3.6	Mains connection	20
4	Operation.....	21
4.1	Connections of the stud welding unit	21
4.1.1	Connecting the ground cable	21
4.1.2	Connecting the stud welding gun	22
4.2	Collet preparation (only for PKM-1B and PHM-1A)	22
4.3	Adjusting the contact stud welding gun PKM-1B.....	23
4.4	Adjusting the gap stud welding gun PHM-1A	24
4.5	Adjusting the special stud welding gun PIM-1B.....	25
4.6	Adjusting the stud welding unit	26
4.7	Tips for good welding results	27
4.8	Work procedure during welding.....	29
4.9	Testing the weld	30
4.9.1	Visual inspection	30
4.9.2	Impact bending test.....	31
5	Maintenance	33
5.1	Troubleshooting	33

5.2	Care and cleaning	37
5.3	Maintenance intervals	38
5.4	Accessories, conversion and consumption parts.....	39
5.5	Fuse elements	44
5.6	Technical data.....	45
6	EC Declaration of conformity	47
7	Spare parts	48
7.1	Spare parts stud welding units.....	48
7.2	Spare parts contact stud welding gun PKM-1B	53
7.3	Spare parts gap stud welding gun PHM-1A	55
7.4	Spare parts special stud welding gun PIM-1B.....	57

1 Introduction

1.1 General information

These operating instructions apply to the stud welding unit type LBS 44, LBS 75 and LBS 80 as well as to the stud welding guns PKM-1B, PHM-1A and PIM-1B. They are intended for the operating and service personnel. Familiarise yourself with the contents of these operating instructions before starting the stud welding unit. You will then achieve better welding results and work safely. In the event of difficulties or confusion please consult the after-sales service of BTH Tech, who will be pleased to help you. The figures, specifications and data given in these operating instructions correspond to the state of development as on November 15th 2008. BTH Tech reserves the right to make technical changes serving to improve the stud welding unit and the stud welding guns.

1.1.1 For your safety

Knowledge of the contents of these operating instructions is essential to ensure safe and trouble-free operation of the stud welding system. Circumstances and requirements change from case to case. Therefore also always comply with your national and the European standards regarding safety (EN).

Set-up personnel

Set-up personnel need knowledge and experience in welding to:

- assess the workplace
- set up the equipment
- select the right welding element

Knowledge in the handling of stud welding systems is also required. This knowledge is trained either by BTH Tech or trained set-up personnel.

Operator

Welding work may only be performed by persons over 18 years of age. Knowledge of welding is presupposed.

Employer

The personnel must be instructed regularly, but at least once a year, according to the current health and safety regulations of BG §1. Untrained or unauthorised personnel may not use the stud welding unit.

1.1.2 Field of application of the stud welding system

The stud welding unit is designed for welding of welding elements (e.g. welding studs according to EN 13918 or special welding elements) on weldable workpiece surfaces by the capacitor discharge stud welding method. The device only works in combination with a suitable stud welding gun. Further applications are possible. If required, please consult with BTH Tech.

1.1.3 Characteristics of the stud welding system

Easy operation

The stud welding unit is easy to use and – except in the case of work subject to official supervision – no special welding qualification is necessary. The partial mechanisation of the welding process means high-quality welding results can be achieved after a short familiarisation period.

Safety

The unit was designed according to EU and national German regulations so that you can work as safely as possible. Work under increased electrical hazard is permitted. The device fulfils the requirements of Protection Class I, IP 23 and comes with the CE mark.

Long life

The capacitors, thyristors, transformers and electronics are especially robust and together with the modern sheet steel housing guarantee long life on the stud welding unit.

1.2 Components of the stud welding system

The stud welding system consists of the **stud welding unit** (LBS 44, LBS 75 or LBS 80), the **stud welding gun** (PKM-1B, PHM-1A or PIM-1B), the **ground cable** and the **collet (chuck)** with the welding element (threaded stud, non-threaded stud, tapped stud etc.).

These operating instructions describe three configurations:

- 1) Stud welding unit LBS 44 / LBS 75 / LBS 80 with contact stud welding gun PKM-1B
- 2) Stud welding unit LBS 44 / LBS 75 / LBS 80 with gap stud welding gun PHM-1A
- 3) Stud welding unit LBS 44 with special stud welding gun PIM-1B

All welding guns can weld normal welding studs. They are fitted with studs manually.

1.3 Functional principle of the stud welding system

Stud welding systems are used to weld metal welding studs (e.g. threaded studs) on to weldable metal workpiece surfaces. The stud welding unit works by the principle of capacitor discharge. Together with a manually fitted welding gun of the type PKM-1B (contact welding gun), PHM-1A (gap welding gun) or PIM-1B (special stud welding gun to weld cupped head pins) it can weld normal welding studs with ignition tips.

The welding energy required is delivered by the stud welding unit, which charges a capacitor battery via a regulator circuit. The welding current is then activated by a power thyristor. The electric circuit is closed by the stud welding gun, welding stud, workpiece and ground cable.

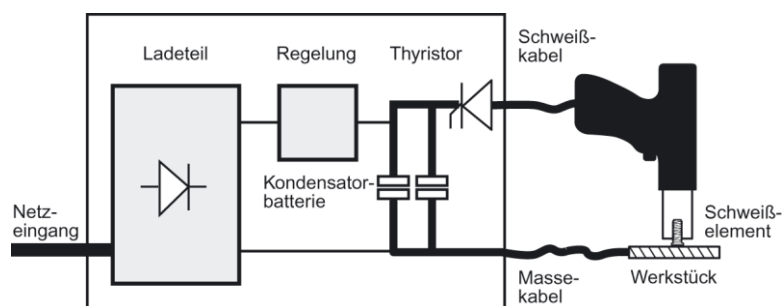

Functional principle of the electric control system

1.4 Contact stud welding gun PKM-1B

Field of application

The PKM-1B is a contact stud welding gun for capacitor discharge stud welding. The welding elements should preferably be of **steel, stainless steel** or **brass**. **Aluminium studs** can also be processed with limitations. Owing to the longer welding time and the deeper penetration, the PKM-1B is especially suitable for oily, rough and difficult surfaces like rolling skin, forging scale and zinc.

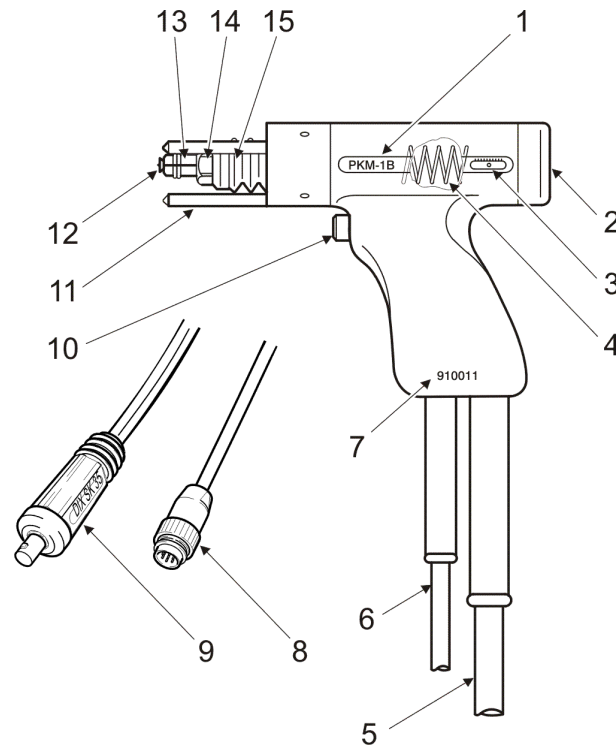

Position	Description
1	Type label
2	Adjusting screw
3	Display for spring pressure
4	Pressure spring
5	Welding cable
6	Control cable
7	Serial number
8	Control cable plug
9	Welding cable plug
10	Start button
11	Gun foot
12	Welding element with ignition tip
13	Colet
14	Lock nut
15	Rubber gaiter

Contact stud welding gun PKM-1B

Method

A welding element is first pushed into the collet of the welding gun. The welding gun is then placed down vertically with the ignition tip of the stud element on the required point on the workpiece and pressed down until all feet are placed on the workpiece (this pushes the plunger against the pressure spring). By pressing the start button the welding current is switched on and the welding process is started. The ignition tip evaporates and generates an arc, which melts the face of the stud and the workpiece. The pre-stressed pressure spring then forces the welding element into the weld pool and the arc is extinguished. The capacitors are discharged completely. The weld pool solidifies. This welding process lasts about 1,5 to 3 ms. Directly afterwards the welding gun can be pulled off the welding element vertically and fitted with a new one.

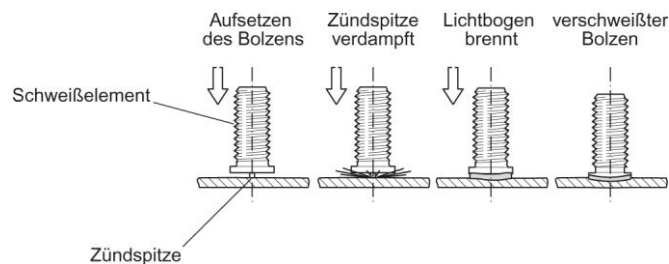

Contact stud welding sequence

1.5 Gap stud welding gun PHM-1A

Field of application

The PHM-1A is a gap stud welding gun for capacitor discharge stud welding. Owing to the short welding time (compared to contact welding) the PHM-1A is also suitable for welding very **thin-walled** workpieces and allows **aluminium welding** without inert gas. With the appropriate settings, all other materials next to aluminium can also be welded.

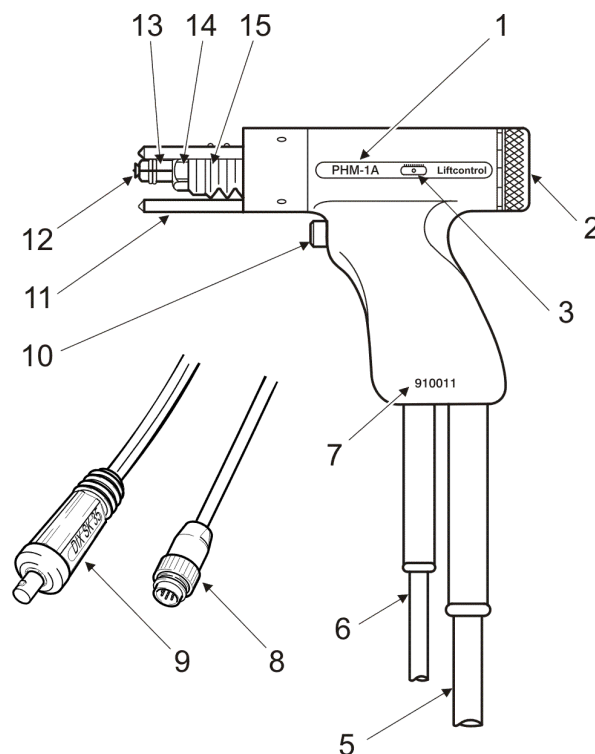

Position	Description
1	Type label
2	Adjusting screw for lift (gap)
3	Display for lift
5	Welding cable
6	Control cable
7	Serial number
8	Control cable plug
9	Welding cable plug
10	Start button
11	Gun foot
12	Welding element with ignition tip
13	Collet
14	Lock nut
15	Rubber gaitor

Gap stud welding gun PHM-1A

Method

A welding element is first pushed into the collet of the welding gun. The gun is then placed down vertically with all feet on the workpiece. When the start button is pressed, the welding element is lifted by a lifting magnet (against a pressure spring). When the end position is reached, the lifting magnet is switched off and the welding current is switched on. The welding element is then accelerated into the direction of the workpiece by the pressure spring. When the ignition tip hits the surface, a large discharging current flows. This evaporates the ignition tip and an arc is generated, which melts the face of the welding element and an approximately equally large area on the workpiece. The welding element then dips into the weld pool, the arc is extinguished and the weld pool solidifies. This welding process lasts about 1 to 3 ms. Directly afterwards the welding gun can be pulled off the welding element vertically and fitted with a new one.

Note:

The higher the lift, the shorter is the welding time. (The lift can be set continuously from 0-5 mm). The wall of the workpiece should be at least 0,5 mm thick.

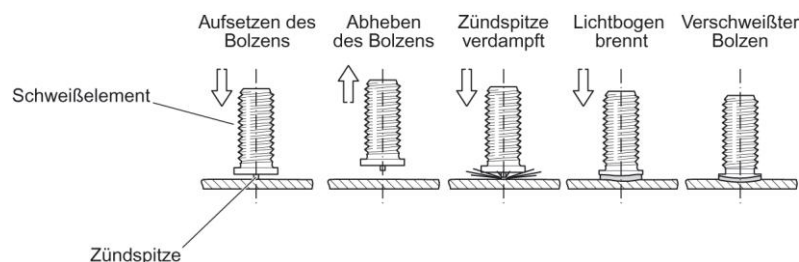

Gap stud welding sequence

1.6 Special stud welding gun PIM-1B

Field of application

The PIM-1B is a special stud welding gun (welding method: capacitor discharge stud welding (contact)) to weld cupped head pins. Cupped head pins (isolated nails with clip) are used to fix isolated mats. The cupped head pins should preferably be of steel or stainless steel. Owing to the longer wel-

ding time and deeper penetration, the PIM-1B is especially suitable for oily, rough and difficult surfaces like rolling skin, forging scale and zinc.

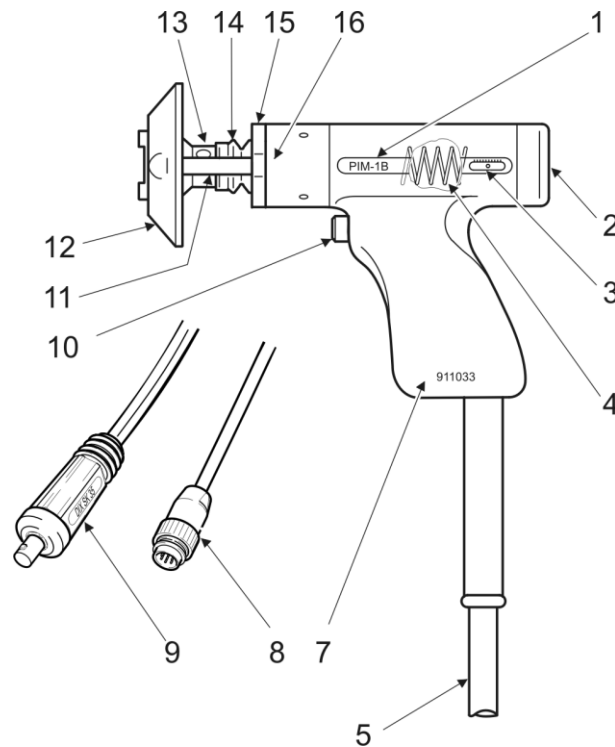

Position	Description
1	Type label
2	Adjusting screw
3	Display for spring pressure
4	Pressure spring
5	Welding cable
7	Serial number
8	Control cable plug
9	Welding cable plug
10	Start button
11	Distance bolt
12	Foot piece TS
13	Magnetic chuck
14	Rubber gaiter
15	Stand plate TS
16	Foot ring

Special stud welding gun for cupped head pins PIM-1B

Method

A cupped head pin is first put onto the magnetic chuck of the welding gun.

Note:

For cupped head pins with a stainless steel clip chucks with a clamp mechanism are used instead of magnetic chucks (see section 5.4). Contact BTH Tech in this regard if necessary.

After that the start button of the welding gun is pressed.

Note:

The start button must be pressed permanently because the welding process is released by a contact switch in the welding gun.

While pressing the start button the welding gun is pushed vertically with the tip of the cupped head pin through the required point of the isolated mat. Because of the pressure of the welding gun onto the workpiece the plunger in the welding gun is pressed against the pressure spring and the contact switch releases the welding in the right position. The pre-stressed pressure spring now presses the cupped head pin into the weld pool and the arc is extinguished. During this process the capacitors are discharged completely. The weld pool solidifies. This welding process lasts about 1,5 to 3 ms. Directly afterwards the welding gun can be pulled off the welding element vertically and fitted with a new one.

1.7 Meaning and functional description of the symbols

The connection sockets, indicators and operating elements on the stud welding unit have the following meaning.

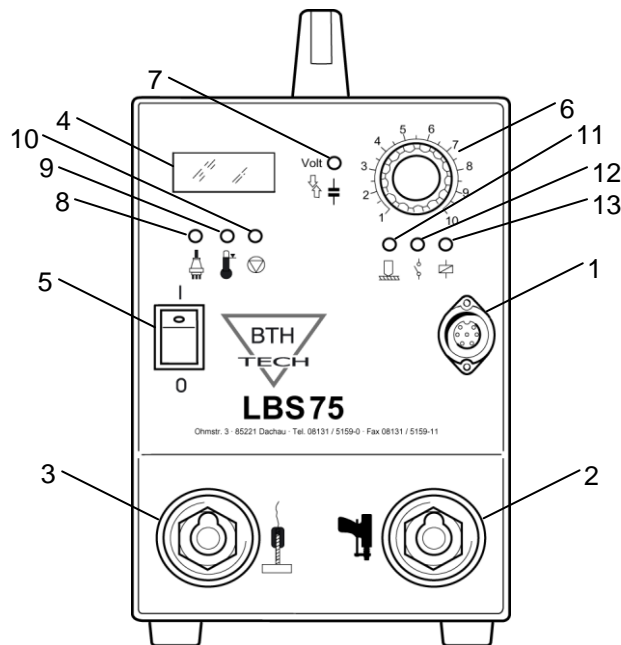

	Description	Function
1	Control cable socket	Connection socket for control cable of the welding gun (to transmit the control signals to the welding gun).
2	Welding cable socket	Connection socket for the welding cable of the welding gun.
3	Ground cable socket	Connection socket for the ground cable.
4	LED-Display	Shows the actual adjusting value of the charging voltage.
5	Main switch I/O	To switch the stud welding unit on / off. Switch positions: I = On [switch lights up green] O = Off
6	Charging voltage regulator	Rotary button to set the energy.
7	Capacitor charge status (ready indicator)	LED lights up red : Capacitor being charged. LED lights up green : Capacitor fully charged and device ready for welding. LED shows no lights: Capacitor being discharged.
8	Mains power	LED lights green : Power supply is OK.
9	Temperature	LED lights red : Temperature in the stud welding unit above 80°C (charging cycles become longer due to the temperature).
10	Blocked	LED lights red : 1) The welding gun has not been pulled of the welding stud after welding. 2) The residual charge was higher than 36 V (therefore the alarm).
11	Contact	LED lights yellow : Contact between the welding element and the workpiece exists.
12	Start	LED lights green : Start button of the welding gun is pressed.
13	Lifting magnet	LED lights yellow : Welding gun with lifting magnet (e.g. PHM-1A) is connected to the stud welding unit.

Connection sockets as well as indicators and operating elements of the stud welding unit

The user can follow the welding process visually by viewing the LED lights:

Execute the start check:

After switching on the stud welding unit the following must light up:

- main switch
- LED-Display (the actual adjusted charging voltage is shown)
- and the LED for
 - mains power
 - capacitor charge status (lights up red for a short time than green (ready indicator))
 - lifting magnet (only if a gap stud welding gun PHM-1A is connected.)

Note:

The LED for the connection of a stud welding gun with a lifting magnet has *no* function when the gun PKM-1B is being used.

- Press the gun with the stud on the workpiece. The contact LED must light up (when ground cable – on both sides – and welding cable are connected).
- Hold the gun in the air and press the start button: the start LED must light up.
- Otherwise no further LEDs should light up.

Troubleshooting

See section 5.1.

1.8 Other descriptions

Ignition tip

The stud welding unit and the connected stud welding gun work by the tip ignition welding method. In order to ignite an arc and therefore to generate a weld pool, every stud must have an ignition tip.

Inert gas

Inert gas is seldom used in tip ignition welding because the short welding time gives little time for oxidation.

1.9 Welding elements (welding studs)

Depending on the accessories of the welding gun threaded studs, non-threaded studs and tapped studs (according to DIN EN ISO 13918) as well as other welding elements with an ignition tip of various sizes and materials can be welded. The following must be observed:

- The diameter of the welding element must not exceed 10 mm.
- The length of the welding stud reaches from 6-40 mm; with intermediate ring (option) over 40 mm.
- A suitable collet must be selected for every welding element.

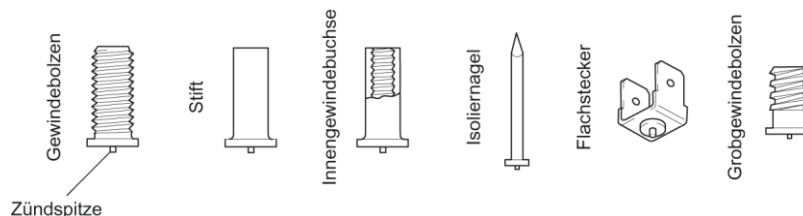

Welding elements for stud welding with ignition tip

1.10 Material combinations

The weldability of workpiece and welding element materials is defined as follows:

1 = weldable; **2** = limited weldability; **0** = not weldable / not tested; * = limited weldability with contact welding gun

Contact and gap welding

Workpiece	Welding element				
	St 37-3 or similar	CrNi-steel (1.4301, 1.4303)	CuZn37 (Ms63)	AlMg3 or similar	Al 99.5
Unalloyed structural steel up to C30	1	1	1	0	0
Steel sheet/plate < 25 µm galvanised	2	2	1	0	0
CrNi-steel 1.4301, 1.4303	1	1	2	0	0
CuZn37 (Ms63)	1	2	1	0	0
AlMg3 or similar	0	0	0	1*	2*
Al 99.5	0	0	0	2*	1*

Suitability of material combinations for capacitor discharge stud welding

Note:

Your BTH specialist advisor will be glad to advise you in the case of material combinations not listed in this table.

1.11 Welding on centre punches or scribed lines

Welding elements with ignition tip can be positioned exactly on centre punches or scribed lines. Since the welding process is started by the ignition tip, the marking must be performed carefully.

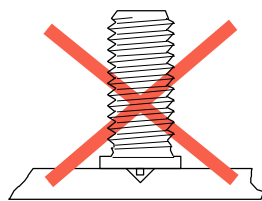

The arc cannot ignite on a centre punch struck too deeply. Should it nevertheless ignite, the strength of the weld is questionable.

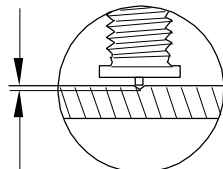

Centre punch depth max. 0.2-0.3mm

Therefore make sure that the depth of the centre punch does not exceed 0,3 mm.

Note:

You can rule out this uncertainty by using an automatic punch (see section 5.4).

2 Work safety and rights

2.1 Safety symbols

Safety instructions and warnings serve your personal safety, the safety of others and the product safety. They are highlighted in these operating instructions by the following terms. These terms draw attention to potentially dangerous or dangerous situations.

Danger:

This additional term means that death, serious physical injury or considerable damage to property will occur, if suitable precautionary measures are not taken.

Warning:

This additional term means that death, serious physical injury or considerable damage to property may occur, if suitable precautionary measures are not taken.

Caution:

This additional term means that slight physical injury or damage to property may occur, if suitable precautionary measures are not taken.

Note:

This additional term introduces important information on proper handling of the product or special information to which attention must be drawn.

The operator of the stud welding system is obligated to allow only those persons to work with the system who are fully acquainted with applicable work safety and accident prevention regulations! All persons working with the stud welding system must read the safety instructions in these operating instructions before commencing work and then observe it!

2.2 Safety instructions

One of the prerequisites for safe handling and fault-free operation of the stud welding unit is knowledge and application of the following information on safety.

Informal safety measures:

- The operating instructions must be kept readily at hand at the place of use of the stud welding unit at all times.
- The safety symbols and type plate on the stud welding unit must be kept in a legible condition.

Personnel training:

- The operating personnel of the stud welding unit must:
 - be instructed in the handling and use of welding equipment
 - know the contents of these operating instructions and be able to apply them
- The start-up personnel and electricians must:
 - have undergone training qualifying them to carry out repair work
 - be qualified to start up electric circuits and equipment in accordance with the standards of safety engineering
- Apprentices and trainees may:
 - only work on the welding system under the supervision of an experienced person

Personal protective equipment:

- Welding generates arcs, a noise level of 107 dB(A) and welding spatter. Therefore the following protective equipment must be worn:
 - fireproof protective clothing covering the whole body

- protective welder goggles with safety glass of protective category 2
- protective gloves
- helmet (for overhead welding)
- ear protection (ear plugs, capsules)

Protective measures at the workplace:

- Only weld in rooms that comply with national legal requirements and the EN requirements.
- Ensure the ambient temperature lies above +5° C, so that a perfect and strong weld joint can be guaranteed.
- Set up the stud welding system such that it is protected against shocks, vibrations and accidental falling over.
- Set up the workplace, so that personnel in the vicinity are protected against the harmful effects of optical radiation.
- Room barriers and protective screens must be set up such that reflections and permeability of radiation are largely avoided.
- Ensure adequate ventilation and lighting of the workplace. Welding of galvanised, leaded or cadmium-plated parts or parts coated with lead paint can give rise to harmful vapours and gases. An extractor must be used in such cases.
- Do not weld in the vicinity of inflammable vapours. The weld or weld spatter could inadvertently cause an explosion.
- Remove combustible or inflammable substances (e.g. paint and cleaning cloths) from a wide area around the welding area. Welding spatter could inadvertently cause a fire. If this is not possible, you must nevertheless ensure a fire cannot be caused by flying sparks (e.g. by covering).
- Ensure that there is a powder fire extinguisher available at the workplace.
- There is a potential danger of burns at all welded workpieces, even if they look "cold" and the welding point is further away. Protect all workpieces against touch, if they have a temperature higher than 50° C. Heated workpieces can also cause fires – through heat conduction.

Caution:

The function of your welding device can be disrupted by the strong electromagnetic fields of other devices (e.g. MIG/MAG devices). Therefore you must arrange sufficient clearance to such devices.

There is an increased danger in hazardous areas as well as in or at containers containing hazardous substances or residues thereof. In these areas welding may only be carried out with the written authorisation of the works manager. The works manager must ensure compliance with all safety regulations.

Only weld in rooms resp. areas, in which no danger from fire, explosions, smoke, vapours or water can arise. In cases of doubt you must consult an authorised welding safety officer or a fire protection officer.

Welding generates strong electromagnetic fields. Therefore you must ensure that all people who can come into the vicinity of the stud welding system are informed about the following points and - as well as yourself - observe them. These electromagnetic fields can:

- threaten the lives of persons with cardiac pacemakers.
- disrupt or damage electric and electronic equipment (e.g. in cars).
- delete irretrievably the contents of magnetic and electronic data media.
- magnetise and therefore damage clocks and watches.

The welding cables also irradiate strong electromagnetic fields. It must be ensured that the cables are laid without loops as far as possible and sufficiently far away from other electric equipment. This applies especially to welding at building sites and on special machines. Consult the respective manufacturer in cases of doubt. The system operator must take suitable remedial measures.

Warning:

The stud welding units are suitable for use in industrial and commercial environment according to EN 55011 (rating class A). Devices of rating class A can cause radio interference in residential and business areas.

Safety measures before commencing work:

- Before commencing any work (e.g. shift change) check:
 - all components of the equipment (e.g. cables) for external signs of damage.
 - all connecting lines for loose contact or scorching.
 - that all protective devices are positioned and connected correctly.

Warning:

Keep body parts (e.g. hand, face) away from the immediate welding area! Heat, welding splatter, radiation etc. can cause irreparable health damage during the welding process.

As soon as the start button is pressed – e.g. for welding – welding element and collet carry current and may not be touched! The welding process can also be started inadvertently, for example when inserting a stud. Therefore never touch workpiece resp. earth and stud at the same time (although the stud welding unit is equipped with a danger reducing device, it can nevertheless happen that you press the start button, which is impossible to protect against). Do not wear electroconductive jewelry such as watches, rings or chains.

- If the stud welding unit has not been switched on for more than two weeks, you should place the power regulator on position 1 and switch on the stud welding unit for about 10 minutes. Afterwards, you can turn the regulator gradually to the highest setting and then switch off again. Only now the stud welding unit is fully functional.

Safety measures during operation:

- Only use the welding system when it is in perfect technical order.
- All working methods that impair safety are strictly forbidden.

Safety measures after finishing work:

- Switch the **main switch** of the stud welding unit to "0" (OFF) and turn the **power regulator** on position 1. This is important especially before longer work breaks (longer than two weeks) because the capacitors could depolarise and explosive gases could arise. The mains plug should also be pulled out before longer work breaks.
- Secure the stud welding unit against unauthorised use.
- Place the stud welding system such that it is protected against shocks, stroke and accidental falling over.
- Should workpieces be hotter than 50° C in places, take precautions to ensure people cannot burn themselves.
- Note and adhere to the stipulated maintenance intervals.

Safety measures in the event of malfunctions:

- Switch off the stud welding unit immediately and pull out the mains plug.
- Secure the welding unit so that it cannot be switched on again and label it as defective.
- Protect hot workpieces against touch.
- After repair work the welding system must be checked to ensure it is fully functional. Check the cables for damage and all safety devices for working order (see section 5.1).

Warning:

Only authorised electricians may open the stud welding unit and work inside the housing. The protective conductor must be connected to the housing again before closing.

Increased electrical danger exists when working:

- in narrow rooms with electroconductive walls.
- in wet, damp, extremely dry and hot rooms.

- in rooms with restricted freedom of movement on electroconductive parts (metal ladders, scaffolds, mounting rails, base plates, etc.).
- under confined conditions between or on electroconductive parts.

Warning:

Only devices marked with an "S" are permitted in these work conditions – capacitor discharge stud welding units are not permitted!

Safety features of the stud welding unit:

The stud welding unit is equipped with the following safety features to protect against direct or indirect contact:

- Protection IP 23: Protection against penetration of foreign objects ($\varnothing = 12,5$ mm).
- Protection against splash water, inclined up to 60° to perpendicular.
- Protection Class I: Device with basic insulation and connection of all touchable, conductive parts with the protective conductor.

Additionally, the stud welding unit is equipped with a safety device (danger reducing device) that measures the voltage between the welding poles. If a voltage of 34 V is exceeded at the welding cable sockets outside the brief welding process time, the capacitors are automatically discharged for safety reasons and the device switches to "blocked". This prevents any danger.

2.3 Proper use

The applicable EN standards and accident prevention regulations were taken into consideration in the development of the stud welding unit. The stud welding unit was built in accordance with the latest level of technology and is safe in operation. Nevertheless, the stud welding unit may pose danger when it is operated by untrained personnel or is used improperly.

Proper use involves adherence to the following points:

- The stud welding unit is designed to weld welding studs with ignition tip (contact and gap stud welding), e.g. threaded studs, non-threaded studs and other welding elements.
- The stud welding gun (PKM-1B, PHM-1A or PIM-1B) may only be equipped with welding studs for which the utilized collet has been designed.
- The stud welding gun (PKM-1B, PHM-1A or PIM-1B) is a handheld device and may not be used in stationary applications.
- The specifications in these operating instructions with respect to combinations of materials and the characteristics of welding elements and base metals must be observed.
- The range of applications for the stud welding unit is restricted to closed industrial and commercial areas. The stud welding unit is only conditionally suitable for use in residential and business areas because it is likely to cause electromagnetic interference to electrical and electronic equipment. In this case the system operator must take suitable precautions.
- The stud welding unit may only be operated with the replacement parts and accessories specified in these operating instructions.
- Configurations of the stud welding unit with welding guns from other manufacturers are not supported.
- Unauthorized constructional changes to the stud welding unit and/or welding gun are not permitted.
- The specified maintenance and inspection routines as well as the replacement of wear parts must be carried out as stipulated.

Proper use of the stud welding system also includes adherence to general and special safety instructions in these operating instructions as well as the applicable UVV accident prevention regulations (BGV A2: UVV "Electrical systems and operating materials" (01.04.1979) and BGV D1: UVV "Welding, cutting and related processes" (01.01.1993)). Violations to proper use or any applications not contained in these instructions are not permitted and could be dangerous. The manufacturer accepts no liability for resultant damage; the risk is borne solely by the user.

2.4 Guarantee and liability

Guarantee and liability claims for personal injury or damage to property are excluded if they can be attributed to one or more of the following causes:

- improper use of the stud welding unit.
- improper use of the stud welding gun.
- non-adherence to the work and safety instructions and information in these operating instructions.
- non-adherence to the operating instructions of the stud welding unit and the stud welding gun.
- incorrect start-up, operation and maintenance of the welding system.
- use of the welding system in residential rooms or offices.
- use in damp, inflammable or explosive environment.
- start-up without properly fitted protective devices.
- improperly conducted repairs.
- repairs by unqualified personnel.
- unauthorised constructional changes to the system.
- non-adherence to the stipulated maintenance intervals.

The stud welding unit and the stud welding gun are only designed for the range of applications specified in section 2.3. Before using the stud welding unit outside its range of applications, consult your BTH specialist advisor, otherwise the guarantee will become void.

For damage and the like arising from operation of the stud welding unit with the welding guns of other manufacturers, no claims of whatever type can be made against BTH Tech unless it can be proven by an expert that the damage was clearly caused by negligent design or manufacture by BTH Tech and this was foreseeable at the time of design.

2.5 Copyright

The copyright of these operating instructions belongs to BTH Tech. These operating instructions contain drawings of technical nature that may not, in whole or in part, be duplicated, used without authorization for competitive purposes or given to others.

3 Installation

3.1 Receiving inspection

The stud welding unit was checked for functional capability before dispatch. It must be checked on delivery for damage and completeness of the parts contained in the extent of delivery. The manufacturer or responsible haulage company must be notified immediately of any transport damage and/or missing parts.

3.2 Storage

If the stud welding unit is not put into operation directly after delivery, it must be stored in a secure place. The complete stud welding unit must be protected adequately against dust and dampness. To preserve the lifetime of the capacitors, the stud welding unit must be switched on for about an hour every six weeks, with the charging voltage being raised gradually from 1 to 10. Then turn the charging voltage regulator back to position 1.

3.3 Transport

To avoid damaging the stud welding unit, it should only be transported using the carry handle.

3.4 Place of use

Use of the stud welding unit is restricted to closed industrial and commercial areas. When using the system in residential and office rooms the operator must take special measures to ensure that the electromagnetic fields arising during welding do not represent a danger to people and property.

Danger:

- Caution! Danger to life! Wearer of cardiac pacemakers must keep clear of the vicinity of stud welding systems.
- The electromagnetic fields arising during welding can disrupt or damage other electric or electronic equipment. For this reason a minimum distance of 10 m must be kept between the welding system and other electric and electronic equipment.
- Do not operate the stud welding unit in the vicinity of data storage media. Their contents may be deleted.
- Use of the stud welding unit in rooms where there is a danger of fire or explosions or in damp rooms is strictly forbidden.
- Chlorinated solvents must implicitly be removed from the welding area. They may not be exposed to the arc radiation.

3.5 Positioning the unit

Place the stud welding unit on a horizontal, vibration-free and non-slip surface. The bearing strength of the surface should be at least twice the weight of the stud welding unit. Due to the design and power of the stud welding unit, thermal stresses occur in the housing. Make sure the air inlet is always kept free. To keep the temperature on a low level the ventilator starts working when the device reaches a temperature of 60° C. To ensure unhindered heat exchange with the surroundings, the stud welding unit must be kept at least 1 m away from other sources of heat.

3.6 Mains connection

The mains cable with plug is located at the back of the unit. The following mains ratings must be noted:

- Mains voltage: 230 V (factory setting)
- Mains frequency: 50 Hz (factory setting)
- Mains fuse: min. 10 A (slow-blow)

The control voltage for all welding gun functions is supplied by the stud welding unit.

Warning:

Please note the following safety measures before connecting the stud welding unit with the power supply.

- Only use mains power sockets with tested protective conductor function. This test must be performed by an electrician.
- Compare the indications on the rating plate with the values of the mains power supply. If they do not correspond consult an electrician to take appropriate steps.

When the above precautions have been taken, the stud welding unit can be connected to the mains power supply.

Note:

If the standard factory setting of 230 V/50 Hz is to be changed to 115 V/60 Hz, you must contact BTH Tech regarding the procedure, the fuse ratings and jumper settings.

Warning:

The stud welding unit may only be opened by an electrician. Before the unit is opened for some reason, it has to be switched off and the power cable has to be disconnected from the mains power supply.

4 Operation

All connection sockets and operating elements are freely accessible on the front panel of the stud welding unit. The mains power plug is located at the back of the unit.

4.1 Connections of the stud welding unit

Please notice that the stud welding unit is designed for connection of the welding guns PKM-1B, PHM-1A and PIM-1B.

Caution:

No guarantee concerning safety and functionality of the stud welding system is accepted when welding guns of other manufacturers are connected. BTH Tech is not liable for damage arising from operation of the stud welding unit with welding guns of other manufacturers.

Warning:

The stud welding unit must be switched off before carrying out any connection work. The main switch has to be in the position "0". All cables have to be laid in a way that no trip hazards occur for people.

4.1.1 Connecting the ground cable

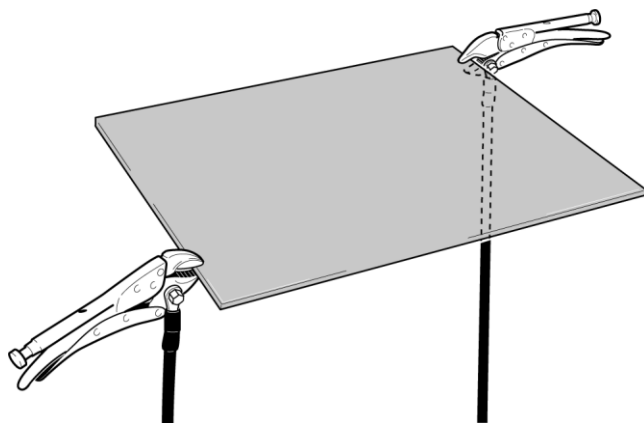

Connect the ground cable directly to the workpiece or the designated workpiece holder (welding bench, welding grate etc.).

Note:

Steel structures, pipes etc may not be used as current conductor if they are not themselves the workpiece that is to be welded.

Warning:

Abide yourself by all safety regulations that come into question and make adequate safety arrangements.

Note:

The welding current circuit may not be earthed. Exception: the workpiece itself is earthed by necessity (steel structure, shipbuilding, pipes etc.).

- The welding point must lie between the two ground clamps: do not place the two ground clamps too close to the welding point and – if possible – position them symmetrically and equidistant to the welding point. In this way you avoid magnetic arc blowing action (= sideways deflection of the arc).

- Plug the ground cable plug into the connection socket (see section 1.7).
- Fasten the ground cable plug in place by turning it firmly clockwise.

4.1.2 Connecting the stud welding gun

- Make sure that the stud welding unit is switched off.
- Plug the welding cable plug into the connection socket (see section 1.7).
- Fasten the welding cable plug in place by turning it firmly clockwise.
- Plug the control cable plug into the corresponding connection socket (see section 1.7) and lock it in place.

4.2 Collet preparation (only for PKM-1B and PHM-1A)

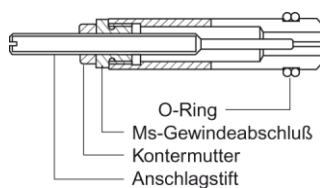

The collet is selected depending on the welding element (welding stud). The suitable collet has to be adjusted to the length of the stud welding element.

Note:

Collets are wearing parts and therefore should be stocked.

Procedure

- Select a **collet** fitting the diameter and form of the welding element.
- Depending on the length of the welding element, fit the **striking pin** in the collet as follows:

a) Welding stud up to **20 mm** length:

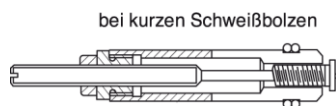

The unthreaded part of the striking pin is located *inside* the collet.

b) Welding stud from **20 to 40 mm** length:

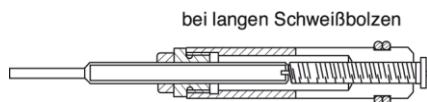

The unthreaded part of the striking pin is located *outside* the collet.

c) Welding stud **over 40 mm** length:

An intermediate ring (accessory part) is additionally required (see section 5.4).

- Equip the collet with the welding element.
- Turn the striking pin until the distance between locknut and stud face is:

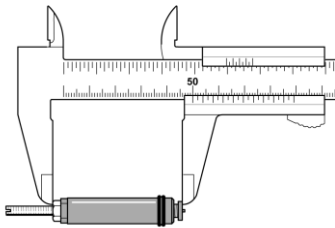

a) when using the PKM-1B: **51 mm** (to max. 53 mm).

b) when using the PHM-1A: **50 mm**.

Note:
Add 12.5 mm when using a collet extension!

Warning:
Switch off the stud welding unit before inserting the collet.

Caution:
The retaining nut may not be tightened when there is no collet in the welding gun.

- Loosen the retaining nut (if it is tight) by turning 90° with the chuck wrench.
- Insert the collet up to the stop into the piston of the welding gun.
- Then tighten the retaining nut firmly.

Caution:
Make sure that the dust bellows is positioned correctly on the retaining nut.

4.3 Adjusting the contact stud welding gun PKM-1B

The electrical and mechanical welding parameters are set at the stud welding unit and on the welding gun.

Welding time

The welding time depends on the **stud speed**. It is adjusted indirectly via the **spring force**. The greater the spring force is, the higher is the speed of the welding element and the shorter is the welding time.

The spring force is set with the adjusting knob (use a coin for this):



Turning clockwise:

The spring force is increased, thereby **reducing** the welding time.

Turning anticlockwise:

The spring force is reduced, thereby **increasing** the welding time.

Caution:
To prevent damage to the adjusting mechanism, never use force to turn the adjusting knob into its end position.

Procedure

Find your material combination and the diameter of the welding element in the following table. Turn the adjusting knob until the spring force indicator on the welding gun shows the value from the table.

Workpiece	Welding element														
	St 37-3 or similar					CrNi-steel (1.4301)					AlMg3 or similar				
	Ø3	Ø4	Ø5	Ø6	Ø8	Ø3	Ø4	Ø5	Ø6	Ø8	Ø3	Ø4	Ø5	Ø6	Ø8
Unalloyed structural steel up to C30	1-2	1-2	1-2	1-2	1-2	1-2	1-2	1-2	1-2	1-2	-	-	-	-	-
Steel sheet/plate < 25 µm galvanised	1-2	1-2	1-2	1-2	-	1-2	1-2	1-2	1-2	1-2	-	-	-	-	-
CrNi-steel 1.4301; 1.4303	1-3	1-3	1-3	1-3	1-3	1-3	1-3	1-3	1-3	1-3	-	-	-	-	-
AlMg3 or similar	-	-	-	-	-	-	-	-	-	-	4-6 ^a	4-6 ^a	4-6 ^a	4-6 ^a	-

Recommended **spring force** [mm] for contact stud welding gun **PKM-1B**

^{a)} Aluminium studs can only be welded with limitations with the contact welding gun PKM-1B.

4.4 Adjusting the gap stud welding gun PHM-1A

The electrical and mechanical welding parameters are set at the stud welding unit and on the welding gun.

Welding time

The welding time depends on the **stud speed**. It is adjusted indirectly via the **lift**. The greater the lift is, the higher is the speed of the welding element and the shorter is the welding time.

The lift is set with the adjusting knob:



Turning clockwise:

The lift is increased, thereby **reducing** the welding time.

Turning anticlockwise:

The lift is reduced, thereby **increasing** the welding time.

Caution:

To prevent damage to the adjusting mechanism, never use force to turn the adjusting knob into its end position.

Procedure

Turn the adjusting knob clockwise to approximately maximum lift. Place the gun nose-down on a flat surface. Turn the adjusting knob anticlockwise until the **stud and all feet of the welding gun lie flat on the surface**. This setting is called "zero lift".

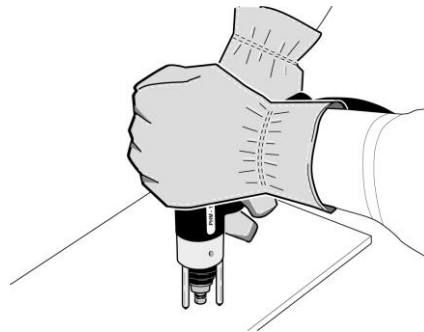

Find your material combination and the diameter of the welding element in the following table. Then set the lift by turning the setscrew clockwise by the specified value.

Note:
One rotation (360°) corresponds to a lift of 1 mm.

Workpiece	Welding element														
	St 37-3 or similar					CrNi-steel (1.4301)					AlMg3 or similar				
	Ø3	Ø4	Ø5	Ø6	Ø8	Ø3	Ø4	Ø5	Ø6	Ø8	Ø3	Ø4	Ø5	Ø6	Ø8
Unalloyed structural steel up to C30	1,5-2	1,5-2	1,5-2	1,5-2	1,5-2	1,5-2	1,5-2	1,5-2	1,5-2	1,5-2	-	-	-	-	-
Steel sheet/plate < 25 µm galvanised	1,5-2,5	1,5-2,5	1,5-2,5	1,5-2,5	1,5-2,5	1,5-2,5	1,5-2,5	1,5-2,5	1,5-2,5	1,5-2,5	-	-	-	-	-
CrNi-steel 1.4301; 1.4303	1,5-2,5	1,5-2,5	1,5-2,5	1,5-2,5	1,5-2,5	1,5-2,5	1,5-2,5	1,5-2,5	1,5-2,5	1,5-2,5	-	-	-	-	-
AlMg3 or similar	-	-	-	-	-	-	-	-	-	-	3-3,5	3-3,5	3-3,5	3-3,5	3-3,5

Recommended lift [mm] for gap stud welding gun PHM-1A

4.5 Adjusting the special stud welding gun PIM-1B

The electrical and mechanical welding parameters are set at the stud welding unit and on the welding gun.

Welding time

The welding time depends on the **stud speed**. It is adjusted indirectly via the **spring force**. The greater the spring force is, the higher is the speed of the welding element and the shorter is the welding time.

The spring force is set with the adjusting knob (use a coin for this):



Turning clockwise:

The spring force is increased, thereby **reducing** the welding time.

Turning anticlockwise:

The spring force is reduced, thereby **increasing** the welding time.

Caution:

To prevent damage to the adjusting mechanism, never use force to turn the adjusting knob into its end position.

Procedure

Find your material combination and the diameter of the welding element in the following table. Turn the adjusting knob until the spring force indicator on the welding gun shows the value from the table.

Workpiece	Welding element														
	St 37-3 or similar					CrNi-steel (1.4301)					-				
	Ø2	Ø2,7	Ø3	-	-	Ø2	Ø2,7	Ø3	-	-	-	-	-	-	-
Unalloyed structural steel up to C30	1-2	1-2	1-2	-	-				-	-	-	-	-	-	-
Steel sheet/plate < 25 µm galvanised	1-2	1-2	1-2	-	-	1-2	1-2	1-2	-	-	-	-	-	-	-
CrNi-steel 1.4301; 1.4303	-	-	-	-	-	1-2	1-2	1-2	-	-	-	-	-	-	-

Recommended **spring force** [mm] for special stud welding gun **PIM-1B**

4.6 Adjusting the stud welding unit

The welding current strength is regulated via the **charging voltage** of the stud welding unit. To set the charging voltage, turn the power regulator to the setting from the following table (or to one determined by yourself).

LBS 44

Workpiece	Welding element														
	St 37-3 or similar					CrNi-steel (1.4301)					AlMg3 or similar				
	Ø3	Ø4	Ø5	Ø6	Ø8	Ø3	Ø4	Ø5	Ø6	Ø8	Ø3	Ø4	Ø5	Ø6	Ø8
Unalloyed structural steel up to C30	65	75	95	140	-	65	75	95	125	-	-	-	-	-	-
Steel sheet/plate < 25 µm galvanised *	75	95	115	145	-	75	95	115	145	-	-	-	-	-	-
CrNi-steel 1.4301; 1.4303	60	65	75	95	-	60	65	75	115	-	-	-	-	-	-
AlMg3 or similar	-	-	-	-	-	-	-	-	-	-	65 ^a	75 ^a	95 ^a	125 ^a	-

* Welding on galvanised steel sheet is possible only with limitations.

LBS 44 (with special stud welding gun PIM-1B)

Workpiece	Welding element														
	St 37-3 or similar					CrNi-steel (1.4301)					-				
	Ø2	Ø2,7	Ø3	-	-	Ø2	Ø2,7	Ø3	-	-	-	-	-	-	-
Unalloyed structural steel up to C30	90	110	115	-	-	-	-	-	-	-	-	-	-	-	-
Steel sheet/plate < 25 µm galvanised *	95	115	120	-	-	95	115	120	-	-	-	-	-	-	-
CrNi-steel 1.4301; 1.4303	-	-	-	-	-	90	110	115	-	-	-	-	-	-	-

* Welding on galvanised steel sheet is possible only with limitations.

LBS 75

Workpiece	Welding element														
	St 37-3 or similar					CrNi-steel (1.4301)					AlMg3 or similar				
	Ø3	Ø4	Ø5	Ø6	Ø8	Ø3	Ø4	Ø5	Ø6	Ø8	Ø3	Ø4	Ø5	Ø6	Ø8
Unalloyed structural steel up to C30	65	75	95	140	180	65	75	95	125	180	-	-	-	-	-
Steel sheet/plate < 25 µm galvanised	75	95	115	145	190	75	95	115	145	190	-	-	-	-	-
CrNi-steel 1.4301; 1.4303	60	65	75	95	145	60	65	75	115	145	-	-	-	-	-
AlMg3 or similar	-	-	-	-	-	-	-	-	-	-	65 ^a	75 ^a	95 ^a	125 ^a	160 ^{a,b}

LBS 80

Workpiece	Welding element														
	St 37-3 or similar					CrNi-steel (1.4301)					AlMg3 or similar				
	Ø3	Ø4	Ø5	Ø6	Ø8	Ø3	Ø4	Ø5	Ø6	Ø8	Ø3	Ø4	Ø5	Ø6	Ø8
Unalloyed structural steel up to C30	60	65	75	115	145	60	65	75	95	145	-	-	-	-	-
Steel sheet/plate < 25 µm galvanised	75	95	115	145	185	75	95	115	145	185	-	-	-	-	-
CrNi-steel 1.4301; 1.4303	60	65	75	95	145	60	65	75	115	145	-	-	-	-	-
AlMg3 or similar	-	-	-	-	-	-	-	-	-	-	65 ^a	75 ^a	95 ^a	115 ^a	160 ^{a,b}

Recommended **settings for charging voltage (V) of the stud welding unit**

^{a)} Aluminium joints can only be welded with limitations with the contact welding gun PKM-1B.

^{b)} Ø8 mm Aluminium joints can only be welded with limitations with the gap stud welding gun PHM-1A.

Note:

The settings in the tables are approximate values only, attained under optimised welding conditions. The settings of the stud welding unit and the stud welding gun must be adjusted to the respective welding job (e.g. basic material) subject to good test weld results (see section 4.9).

Caution:

Frequent dimming of the charging voltage between high fields (e.g. 200 V to 100 V or 150 V to 70 V) can cause damage to the unit. It is recommended to switch off the unit, turn back the power regulator and then switch on the unit again.

4.7 Tips for good welding results

The following tips contain important information on how to achieve good weld joints.

- The welding element and the workpiece must be weldable. Only use material combinations specified in these operating instructions (otherwise suitable tests must be carried out beforehand to confirm the necessary quality features).
- The maximum roughness of the welding zone should not exceed 80 µm.
- The welding zone should be metallically bright: Workpieces of aluminium or with aluminium coating may only be cleaned with a rust-free wire brush. Carefully remove all soiling like rust, scale, paint, moisture, grease and oil. Strip anodised workpiece surfaces with caustic soda lye or grind them clean.
- The welding site must be designed so that there is always a surface of at least Ø 40 mm available to receive the footpiece. When using centring tubes or similar, at least Ø 20 mm.

- Make sure the workpiece is supported such that it is free of vibrations. This is especially important in the case of large and thinwalled workpieces.
- Always lay the welding and ground cables free of loops. In this way electromagnetic influences can largely be avoided.
- Fasten the ground clamps symmetrically to the welding point and not too close to it. In this way flaws in the weld quality caused by arc blowing can be avoided.
- Make sure there is a good transfer of current (low resistance) at all contact points in the welding circuit (welding cable connections, collet, ground cable connection, ground clamps).
- Observe the necessary settings on the welding gun and on the stud welding unit for your welding job.
- The welding gun and the workpiece may not be moved during the welding process.
- Always pull the gun off the welding element vertically. This prevents overstretching of the collet blades.
- Avoid welding on one workpiece with more than one welding system at the same time (possible influence on the arcs).
- In order to check that the settings of the stud welding unit and the welding gun are correct, a number of trial welds should always be performed before commencing work. The quality of the welding results must be checked.
- Check the clamping force of the collet blades from time to time and bend them together a little, if necessary. This increases the lifetime of the collet.

4.8 Work procedure during welding

Before commencing welding work make sure that the welding gun and the stud welding unit are connected correctly and the set values correspond to the welding job. Observe the following safety information.

Warning:

All persons working with the welding system must observe the safety information in section 2 before commencing work! When the start button is pressed, the collet and the welding element carry current. These parts may *not* be touched during welding!

Preparing the welding gun PKM-1B, PHM-1A and PIM-1B:

- Equip the gun with a suitable collet.
- Set the "spring force" (for PKM-1B and PIM-1B) resp. the "lift" (for PHM-1A) according to the instructions (see section 4.3, 4.4 and 4.5).
- Insert a welding element into the collet.

Preparing the stud welding unit:

- Switch on the stud welding unit. Carry out the **start check** (see page 12).
- Set the charging voltage according to the approximate values specified in section 4.6.
- A number of trial welds must be carried out (with the specified values) to find the optimum setting.

Work procedure with PKM-1B and PHM-1A:

- If not already done, insert a welding element into the collet. Position the welding gun on the welding point vertically. The contact LED lights up.
- Press the welding gun vertically (90°) against the workpiece surface with both hands.
- Hold the welding gun steady and press the start button. The welding process is started. At the same time the start LED lights up (and the contact LED goes out briefly if a PHM-1A is connected). The blocked LED lights up. A trigger block prevents the welded welding element from being welded again. The stud welding unit remains discharged.

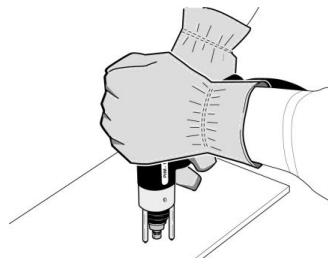

- After welding remove the gun vertically from the welded welding element. The LED "blocked" and "contact" go out and the stud welding unit charges the capacitors for the next welding operation.

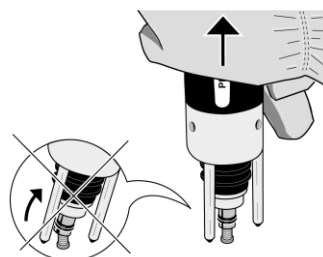

- Check the welding result in accordance with section 4.9. If the welding result is not satisfactory, the settings must be optimised.

Work procedure with PIM-1B:

- If not already done, put a mini-cupped head pin onto the collet. Press the start button of the welding gun.
- While pressing the start button push the face of the mini-cupped head pin vertically (90°) through the required point of the isolated mat.
- Press the welding gun onto the workpiece until the welding is released. The welding process is started. At the same time the start LED lights up. The blocked LED lights up. A trigger block prevents the welded welding element from being welded again. The stud welding unit remains discharged.
- After welding remove the gun vertically from the welded welding element. The LED "blocked" and "contact" go out and the stud welding unit charges the capacitors for the next welding operation.
- Check the welding result in accordance with section 4.9. If the welding result is not satisfactory, the settings must be optimised.

Warning:

After finishing the welding process or after longer work breaks the unit has to be switched off, separated from the mains and secured against unauthorised use.

4.9 Testing the weld

Testing of the weld is restricted to a tensile test and visual inspection of the welded stud. Further testing is possible, but complex. Consult your BTH specialist advisor or study DVS guideline 0905 part 2 in this regard. If a weld is thought to be defective, an impact bending test according to section 4.9.2 must be carried out on the welding stud concerned.

4.9.1 Visual inspection

Every welded welding element must be checked visually. Besides assessing the **weld bead**, form and weld spatter, you should also check the **nominal length** of the welded stud.

Good welding

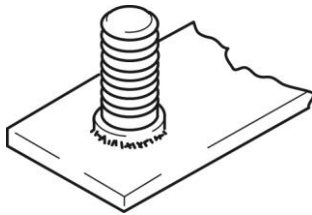

The bead is closed and has a shiny surface. There is no visible undercutting at the bottom of the welding element. Small notches between weld bead and stud shaft are unavoidable and can be ignored.

Welding too hot

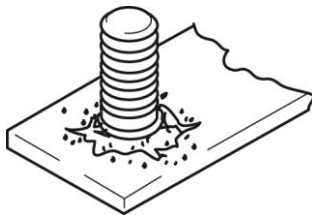

Deep notches can be seen between weld bead and stud shaft. Due to the excess heat, the melt zone at the stud middle is recessed. The excess weld metal was flung out of the welding zone. (Spring force or lift too low.)

Welding too cold

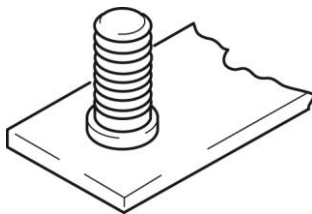

The form and height of the weld bead are irregular. Distinct undercutting can be seen at the stud edge. Due to the low energy, the melt zone under the complete stud cross-section is very flat. (Spring force or lift too high.)

Welding too irregular

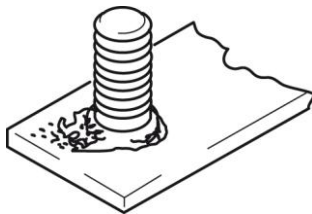

The weld bead is asymmetrical (as a result of magnetic arc blowing action) and the stud edge is undercut on one side. (Possibly change ground clamp positions.)

4.9.2 Impact bending test

The impact bending test is one of the most common test methods to check welding parameters and to identify defective welds. If a weld joint is thought to be defective or the fusion length of the stud is too short, the impact bending test must be carried out as follows:

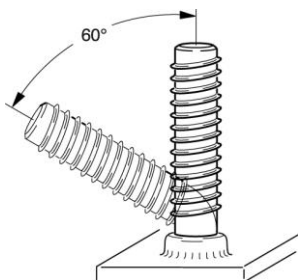

Bend the welding element by 60° (with a hammer or bending device (see section 5.4)). This stresses the weld joint in tension, pressure and bending by an undefined amount.

The impact bending test is deemed as passed if there are no cracks to be seen in the welding zone. If the welding element is torn out of the base metal (a recess is formed in the workpiece) or the stud breaks, the weldability of the materials is deemed proven.

If the welding element breaks off in the welding zone, you must check whether:

- both materials are weldable,
- the material combination is weldable,
- the ignition tip is in order,
- the settings on the welding gun and on the stud welding unit are correct and
- the welding gun or the stud welding unit is defective.

If these requirements are not met, an impact bending test must also be carried out on the three previous and three next welds.

Warning:

The welding work may only be continued when satisfactory test results are obtained!

5 Maintenance

5.1 Troubleshooting

In the event of a malfunction proceed as follows:

- Switch off the stud welding unit.
- Unscrew the control, ground and welding cables from the stud welding unit.
- Switch on the stud welding unit.
- If in addition to the main switch, the mains power LED and the capacitor charge status LED any other LED lights up, switch off the stud welding unit again and contact BTH Tech.

Warning:

In the event of a system malfunction the stud welding unit must be switched off, disconnected from the mains and secured so that it cannot be switched on again!

If no other LED lights up, you can take the following remedial measures:

Warning:

Faults in the stud welding unit requiring the housing to be opened may only be repaired by authorised electricians! Faults in the welding gun requiring only replacement of mechanical replacement parts can be repaired by skilled personnel with the aid of the explosion drawings (see section 7.2 and 7.3) After repair a function test of the protective circuits must be carried out by an electrician! Only replacement parts specified in the corresponding part lists may be used to replace parts! Malfunctions that cannot be repaired by the remedial measures listed below may only be repaired by BTH Tech or authorised repair technicians.

1. First carry out the **start check** (see page 12). If one test result is negative, continue with the relevant point in the following table.

Indicators

Situation	Cause	Remedy
Main switch does not light up although it is switched on.	<ul style="list-style-type: none"> • Stud welding unit not connected <p><u>Fault in:</u></p> <ul style="list-style-type: none"> • Main switch or lamp • Power cable breakage • Mains power plug • Mains fuse 	<ul style="list-style-type: none"> • Connect stud welding unit and switch on! <p><u>Check* and replace* if necessary:</u></p> <ul style="list-style-type: none"> • Main switch or lamp • Power cable with plug • Mains fuse (in switch box)
Main switch lights up, mains power LED does not light up.	Fuse defective	Replace fuse in stud welding unit* (see section 5.5)
Power-LED is glowing, display is not glowing.	Fuse defective	Replace fuse * (see section 5.5)
PHM-1A is connected, but LED "magnet" does not light up.	Control cable damaged (e.g. loose contact); lifting magnet in gun defective	Connect another gun and check whether LED then lights up; replace cable or lifting magnet if necessary*
No PHM-1A is connected, but LED "magnet" lights up.	Fault in stud welding unit	Shut down the stud welding unit and mark as defective, so that it is not switched on again; notify BTH Tech after sales service.
LED "blocked" lights up.	<ul style="list-style-type: none"> • Malfunction • Fault in stud welding unit 	<ul style="list-style-type: none"> • Switch the stud welding unit off and then on again. If LED does not light up again, continue working. • Shut down the stud welding unit and mark as defective so that it is not switched on again; notify BTH Tech after sales service.
Ready LED does not light up.	Fuse defective	Replace fuse* (see section 5.5)
Contact LED does not light up on contact with the workpiece.	<ul style="list-style-type: none"> • No ground or welding cable connected • Cable defective • Stud welding unit defective 	<ul style="list-style-type: none"> • Connect ground, control and welding cables to the stud welding unit. • Replace cable if necessary • Notify BTH Tech after sales service
Start LED does not light up, although the start button is being pressed.	<ul style="list-style-type: none"> • Control cable not connected to stud welding unit • Control cable defective • Gun defective • Stud welding unit defective 	<ul style="list-style-type: none"> • Connect and fix cable • Replace cable if necessary • Connect another gun and test LED again • Notify BTH Tech after sales service
Start LED lights up, although the start button is not being pressed.	<ul style="list-style-type: none"> • Short circuit in control cable or • Start button defective 	<ul style="list-style-type: none"> • Replace control cable or start button if necessary

*** Check only by electricians!**

Troubleshooting using LED indicators

Malfunction or change

Situation	Cause	Remedy
Charging cycle takes longer, temperature LED lights up.	Temperature of the stud welding unit is high.	Clear air slots of the stud welding unit if appropriate; keep adequate distance between the stud welding unit and other objects; remove heat sources from environs; shield against heat radiation
Welding is not released.	Welding element does not have an ignition tip.	Insert welding element with ignition tip in collet and repeat welding
	Control cable defective	Check control cable and replace if necessary
	Gun microswitch defective	Check microswitch and replace if necessary
	Control board defective	Replace control board* or notify BTH Tech after sales service
* Check only by electricians!		

Defective welds or malfunctions

Caution:

Never weld with an overlarge or expanded collet because the collet will be damaged. Never weld without a stud because the collet will then also be damaged.

Welding result defective

- The **start check** (see page 12) has been carried out (indicators are okay).
- Defective welding results were achieved.

Situation	Cause and remedy
Defective weld	<ul style="list-style-type: none"> • Set correct charging voltage (see section 4.3 and 4.4) • Set welding gun (see section 4.3 and 4.4) • generally: study and apply section 4.3 - 4.9
"Cold weld"	<ul style="list-style-type: none"> • Piston stiff → clean or replace • welding time too short (spring force or lift too high)
"Very hot weld"	<ul style="list-style-type: none"> • Welding time too long (spring force or lift too low)
"Poor weld", stud does not hold	<ul style="list-style-type: none"> • Excess weld splatter, stud does not lift off → Increase spring force or lift significantly, → Clean or replace gun piston
Stud shaft or stud thread scorched	<ul style="list-style-type: none"> • Collet does not match the welding element dimensions → use a suitable collet • Collet has been expanded → retighten or replace (in future pull off the gun vertically from the welding studs)
Constantly changing welding results	<ul style="list-style-type: none"> • Place gun vertically on workpiece ; replace feet if necessary • Gun piston is stiff → clean or replace
Irregular weld	<ul style="list-style-type: none"> • Gun piston is stiff → clean or replace
Arc drop during welding (poor weld)	<ul style="list-style-type: none"> • Clean welding point of oil, grease and other contamination • Check workpiece of deflection • Check spring force or lift • Clean supporting feet or supporting tube • Optimise ground clamp position
Welding stud crooked	<ul style="list-style-type: none"> • Place gun vertically on workpiece • Replace worn or bent leg • Replace positioning tube
Welds with distinct beading on one side (blowing action)	Eliminate magnetic arc blowing action by: <ul style="list-style-type: none"> • changing the position of the welding cable • changing the position of the ground clamps (see section 4.1.1) • bringing in additional plates or iron parts
* Check only by electricians!	

Defective welding results

5.2 Care and cleaning

The stud welding system does not require any special care. The following cleaning work is nevertheless recommended. The cleaning intervals depend on the degree of soiling, but should not exceed six months.

Warning:

The stud welding unit must be switched off and disconnected from the mains power supply before cleaning.

Welding gun

It must be ensured that the handle of the welding gun is always dry, clean and free of greases and oils.

Caution:

No aggressive agents, agents containing alcohol or inflammable liquids may be used for cleaning.

Collets soiled with weld spatter must be cleaned with a brass wire brush.

Stud welding unit

The housing must be wiped with a damp cloth. The rating plate and safety information must be kept in a legible condition.

Caution:

No aggressive agents, agents containing alcohol or inflammable liquids may be used for cleaning.

The front panel of the stud welding unit must be cleaned with a fat dissolving cleaning agent. The LED indicators must be clearly readable in operation.

Connecting cables

All connecting cables must be cleaned with a dry cloth. Scorched sites or mechanical defects can thereby be detected easily. The cables must be replaced if necessary.

Inside the device

It might also be necessary to clean the inside of the device, if it is very dirty.

Warning:

Only authorised electricians may open the stud welding unit and work inside the housing. Before the unit is opened it must be switched off, disconnected from the mains power supply and secured so that it cannot be switched on again.

Dirt and contamination inside the stud welding unit like metallic dust or conductive chips must be sucked off. They may not be blown out with compressed air!

Warning:

After the cleaning work the device must be restored to and handed over in orderly condition so that – when used properly in accordance with these instructions – it does not pose a danger to the user or the environment.

5.3 Maintenance intervals

You can avoid malfunctions caused by inadequate maintenance by adhering to the following maintenance intervals. The maintenance intervals and instructions specified in the table below presuppose proper use under normal conditions.

Warning:
Maintenance work requiring the stud welding unit to be opened may only be carried out by authorised electricians!

Maintenance intervals	Maintenance instructions
Every 8 hours or daily	<ul style="list-style-type: none"> • Check the welding cable, ground cable, control cable and power cable for external damage – replace defective cables immediately. • Check the collet (= wearing part) for adequate clamping force and wear; replace if necessary. • Check the welding cable plugs for firm connection; tighten if necessary (replace scorched plugs). • Check the retaining nut of the gun for firm seating; tighten if necessary. • Check the dust bellows for correct seating and adjust if necessary → replace if damaged. • Check the gun piston for free movement → clean with a brass brush.
Every 35 hours or weekly	<ul style="list-style-type: none"> • Check connections and operating elements. • Make sure the LED work.
Every 800 hours or half-yearly	Stud welding unit: <ul style="list-style-type: none"> • Check for dirt and contamination* inside the housing and clean* according to section 5.2. • Check all screw connections.
Every two years	<ul style="list-style-type: none"> • General inspection of the stud welding unit by repair technician and electrician.
<i>* Check only by electricians!</i>	

Periodic maintenance intervals

Warning:
After the cleaning work the device must be restored to and handed over in orderly condition so that – when used properly in accordance with these instructions – it does not pose a danger to the user, other people or the environment.

5.4 Accessories, conversion and consumption parts

Collets STD (for PKM-1B and PHM-1A)

Standard collets are used for threaded studs, tapped studs and non-threaded studs.

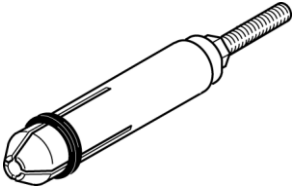
	Part number	Description
	B-90-50-1011	Collet accessory set STD consisting of: Collet ø 3 mm STD Collet ø 4 mm STD Collet ø 5 mm STD Collet ø 6 mm STD Collet ø 8 mm STD Chuck wrench SW 17 STD (Article no. B-80-40-1070)
	82-50-002	Collet ø 2 mm STD
	82-50-003	Collet ø 3 mm STD
	82-50-004	Collet ø 4 mm STD
	82-50-005	Collet ø 5 mm STD
	82-50-006	Collet ø 6 mm STD
	82-50-071	Collet ø 7,1 mm STD
	82-50-008	Collet ø 8 mm STD
	82-50-010	Collet ø 10 mm STD

Collet ISO (for PKM-1B and PHM-1A)

ISO collets are used for insulating nails.

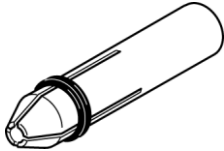
	Part number	Description
	82-50-020	Collet ø 2 mm ISO
82-50-030	Collet ø 3 mm ISO	

Collet FS (for PKM-1B and PHM-1A)

FS collets are used for earth plugs and double earth plugs.

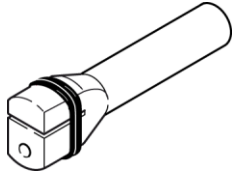
	Part number	Description
	82-50-050	Collet FS

Collet TS (for PIM-1B)

TS collets are used for cupped head pins.

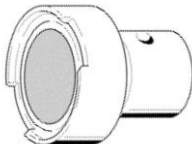
	Part number	Description
	82-50-0311	Magnetic collet ø 30 mm
	82-50-308	Magnetic collet ø 38 mm
82-50-0303	Clamping collet ø 30 mm	

Angle bracket (for PKM-1B and PHM-1A)

With the angle bracket it is possible to come as close as 8 mm to a rectangular surface with the gun and weld studs.

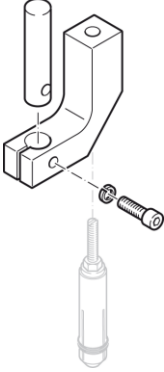
	Part number	Description
	B-90-50-1029	Angle bracket

Bending device

The bending device is used for the impact bending test (see section 4.9.2). It is made in accordance to DIN 0905, part 2. The five inserts must be ordered separately.

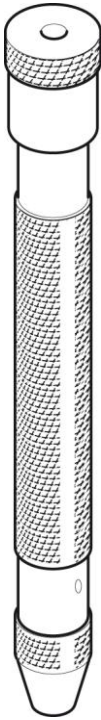
	Part number	Description
	B-80-40-1310	Bending device
	B-80-40-1303	Insert ø 3 mm
	B-80-40-1304	Insert ø 4 mm
	B-80-40-1305	Insert ø 5 mm
	B-80-40-1306	Insert ø 6 mm
B-80-40-1308	Insert ø 8 mm	

Centring device (for PKM-1B and PHM-1A)

The centring device serves for the exact positioning of studs using a welding template.

Note:

If many different studs are being welded to one surface, you can largely prevent the possibility of mixing up the studs by using a template with different-sized centring bores (a different centring-bore diameter per stud type).

Welding templates should preferably be made of materials like aluminium, plastic or hard paper. Approximately 3 mm high spacers must be provided underneath a template so that the welding gases can escape.

No.	Part number	Description
-	B-90-50-21XX	Centring device \varnothing XX mm Foot ring \varnothing 32 mm
8	B-80-40-01XX	Centring tube \varnothing XX mm
9	B-80-40-13XX	Centring disk \varnothing XX mm
1	B-80-40-1407	Foot ring TK 38/32
2	B-80-40-1240	Distance bolt 10-17-M4x5
3	B-80-40-1241	Flange ZV
4	B-80-15-1054	Cylinder bolt 10x70/6325
5	B-90-50-1040	Collet extension 12,5 mm complete with length stop

Explanation to part numbers:

- \varnothing 20 mm – substitute **XX** in the part number with the number **20**
- \varnothing 22 mm – substitute **XX** in the part number with the number **22**
- \varnothing 26 mm – substitute **XX** in the part number with the number **26**
- \varnothing 30 mm – substitute **XX** in the part number with the number **30**

Montage:

- Remove the standard foot ring by loosening the three grub screws (A) on the circumference of the welding gun.
- Mount the centring device (B) and fasten it.

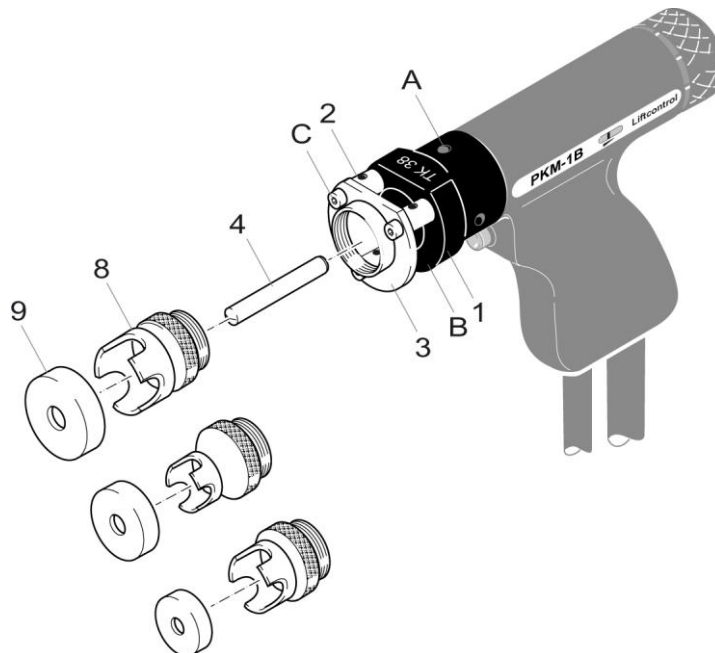

Montage of centring device

- Loosen the retaining nut by turning 90° with a chuck wrench.
- Insert the cylinder bolt (4) into the gun instead of the collet.
- Fix the retaining nut with the chuck wrench.
- Screw the centring tube (8) you have chosen into the centring device.
- Loosen the three screws (C) if necessary.

- Place the centring disk (9) on the cylinder bolt (4) and then on the centring tube (8).
- Fasten the three screws (C). The centring tube is now positioned centrally in relation to the studs.
- Then take off the centring disk and remove the cylinder bolt after loosening the retaining nut.
- Replace the striking pin with counter nut and brass thread end in the collet with the collet extension (5).

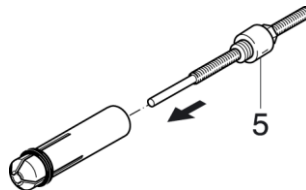

- Place a stud in the collet and set the length (see section 4.2).
- Place the collet equipped this way into the gun and tighten the retaining nut again with the chuck wrench.

Collet extension (for PKM-1B and PHM-1A)

The collet extension is only used when using a centring device.

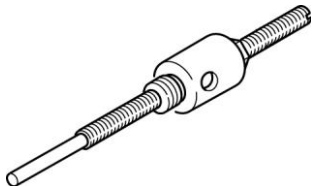
	Part number	Description
	B-90-50-1040	Collet extension

Automatic punch

Part number	Description
B-80-10-1213	Automatic punch

Sound insulating tube (for PKM-1B and PHM-1A)

The sound insulating tube subdues noise to under 82dB(A). It also acts as protection shield in overhead welding because it blocks off a great deal of welding spatter.

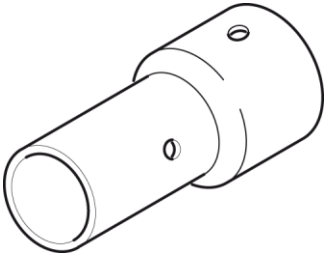
	Part number	Description
	B-90-50-1036	Sound insulating tube ø 35 mm

Positioning tube (for PKM-1B and PHM-1A)

The positioning tube serves for the positioning of studs using a welding template. It is cheaper, but not as accurate as the centring device.

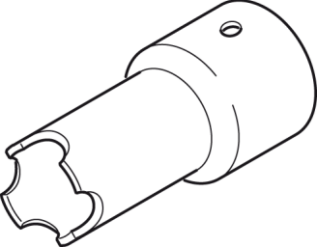
	Part number	Description
	B-90-50-1012	Positioning tube ø 30 mm

Intermediate ring (for PKM-1B and PHM-1A)

An intermediate ring is needed when using welding studs **longer than 40 mm**.

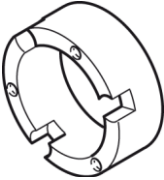
	Part number	Description
	B-80-40-1128	Intermediate ring 16 mm

Montage of intermediate ring:

Remove the three feet. Screw the intermediate ring (1) on tight with the allen screws (2). Then screw the feet into the intermediate ring.

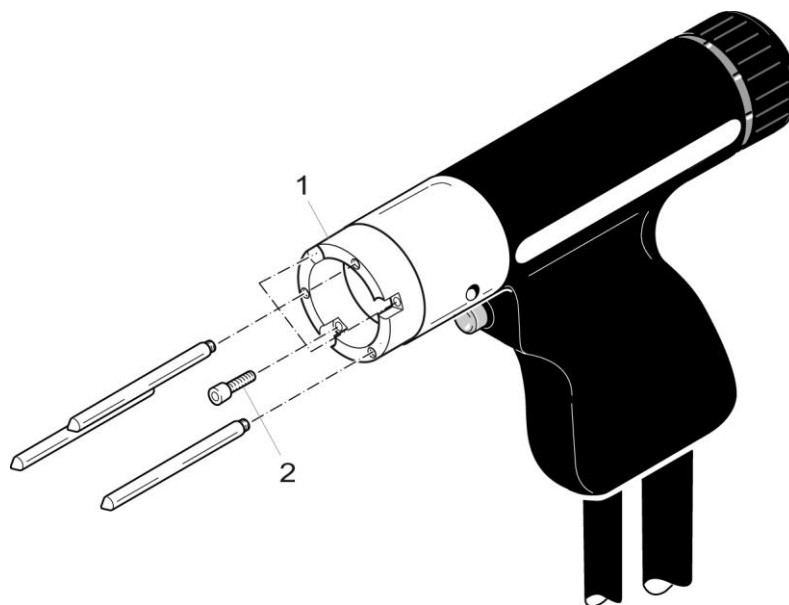

Montage of intermediate ring

5.5 Fuse elements

To protect against impermissible high currents on the back of the unit there are four fuses to protect the following control current circuits:

- F1: Gun lifting magnet fuse
- F2: Control voltage fuse
- F3: Fuse for digital display
- F4: Mains fuse

The mains power socket to which the stud welding unit is connected should be protected with a fuse of at least 10 A.

Fuse	Rated current	Rated voltage	Response
F1	4 A	250 V	fast
F2	1 A	250 V	medium time lag
F3	0,25 A	250 V	fast
F4	4 A	250 V	fast

Fuses in the stud welding unit

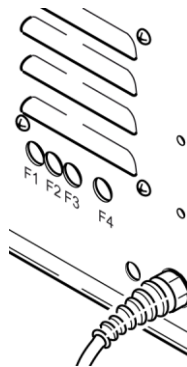

Back view with fuses

Warning:
Always replace defective fuses with like fuses of identical ratings.

5.6 Technical data

	LBS 44	LBS 75	LBS 80
Welding method	Capacitor discharge stud welding (contact and gap method)		
Input voltage/ frequency	~230 V(±10%) / 50 Hz, convertible to: ~115 V(±10%) / 60 Hz (see section 3.6)		
Main fuse external	≥ 10 A		
Capacitance	max. 44.000 µF	max. 66.000 µF	max. 88.000 µF
Charging voltage	60 bis 200 V, continuously adjustable		
Fuses:			
Gun (lifting magnet)	F1: 4 A / 250 V (fast)		
Control voltage	F2: 1 A / 250 V (medium time lag)		
Fuse for digital display	F3: 0,25 A / 250 V (fast)		
Mains voltage	F4: 4 A / 250 V (fast)		
Protection	IP 23		
Protection class	I (one)		
Dimensions (l x w x h)	400 x 165 x 270 mm		
Weight	10 kg	12 kg	13 kg
Power cable	length: 3 m; line cross section 3 x 1,5 mm ²		

Ground cable (standard)	
1 plug, 2 clamps	
Length, line cross section	2,5 m, 2 x 25 mm ²

PKM-1B	
Type	Contact stud welding gun PKM-1B
Welding range	≤ 10 mm
Weight	0,6 kg (without cable)
Noise level	max. 107 dB(A)
Welding cable length, welding cable line cross section	6,5 m, 25 mm ²
Control cable length, control cable line cross section	6,7 m, 3 x 0,5 mm ²
Dimensions (l x w x h)	184 x 40 x 130 mm

PHM-1A	
Type	Gap stud welding gun PHM-1A
Welding range	≤ 10 mm
Weight	0,7 kg (without cable)
Noise level	max. 107 dB(A)
Welding cable length, welding cable line cross section	3 m, 25 mm ²
Control cable length, control cable line cross section	3,2 m, 5 x 0,5 mm ²
Dimensions (l x w x h)	184 x 40 x 130 mm

PIM-1B	
Type	Special stud welding gun PIM-1B
Welding range	≤ 3 mm
Weight	0,9 kg (without cable)
Noise level	max. 107 dB(A)
Welding cable length, welding cable line cross section	10 m, 4 x 2,5 mm ²
Control cable length, control cable line cross section	10 m, 3 x 0,5 mm ²
Dimensions (l x w x h)	193 x 40 x 130 mm

For the procurement of replacement parts for the stud welding units and guns see the explosion drawings in section 7.

Warning:

Repair work on the stud welding unit may only be carried out by electricians. It is expressly pointed out that the parts may only be stripped to the degree of dismantling shown in the explosion drawings!



6 EC Declaration of conformity

Product name: LBS 44 / LBS 75 / LBS 80 with PKM-1B / PHM-1A / PIM-1B

Stud welding system for capacitor discharge stud welding by contact and gap method

	Serial number
Stud welding unit	
Contact stud welding gun	
Gap stud welding gun	
Special stud welding gun	

These devices are developed and manufactured in accordance with the following EC directives:

Machinery 98/37/EC

Low voltage 73/23/EEC, last amended by 93/68/EEC

Electromagnetic tolerance EMV 89/336/EEC as amended on 93/97/EEC

Conformity with the above-mentioned EC directives is verified by adherence to the following European standards:

EN 50199, EN 55011, EN 60204-1, EN 60974-1, EN 292-1, EN 292-2, EN 60529, EN 1050 und DIN EN ISO 9001

under application of the following national standards:

VDE 0100, VDE 0110, VDE 0113, VDE 0544, VDE 0627

under application of the following national specifications:

BGV A1, BGV A2, BGV D1
UWG 26 Welding, cutting and related processes
UVB 56

BTH Tech hereby declares its sole responsibility for manufacture of the above devices. This declaration only applies to the device in its original condition as manufactured by us. It is invalidated by changes to the stud welding system or its parts by third parties.

Dachau, 9.11.08
Place, date



Rüdiger Bolte
Executive director



Friedrich-Peter Schöler
Executive director

7 Spare parts

7.1 Spare parts stud welding units

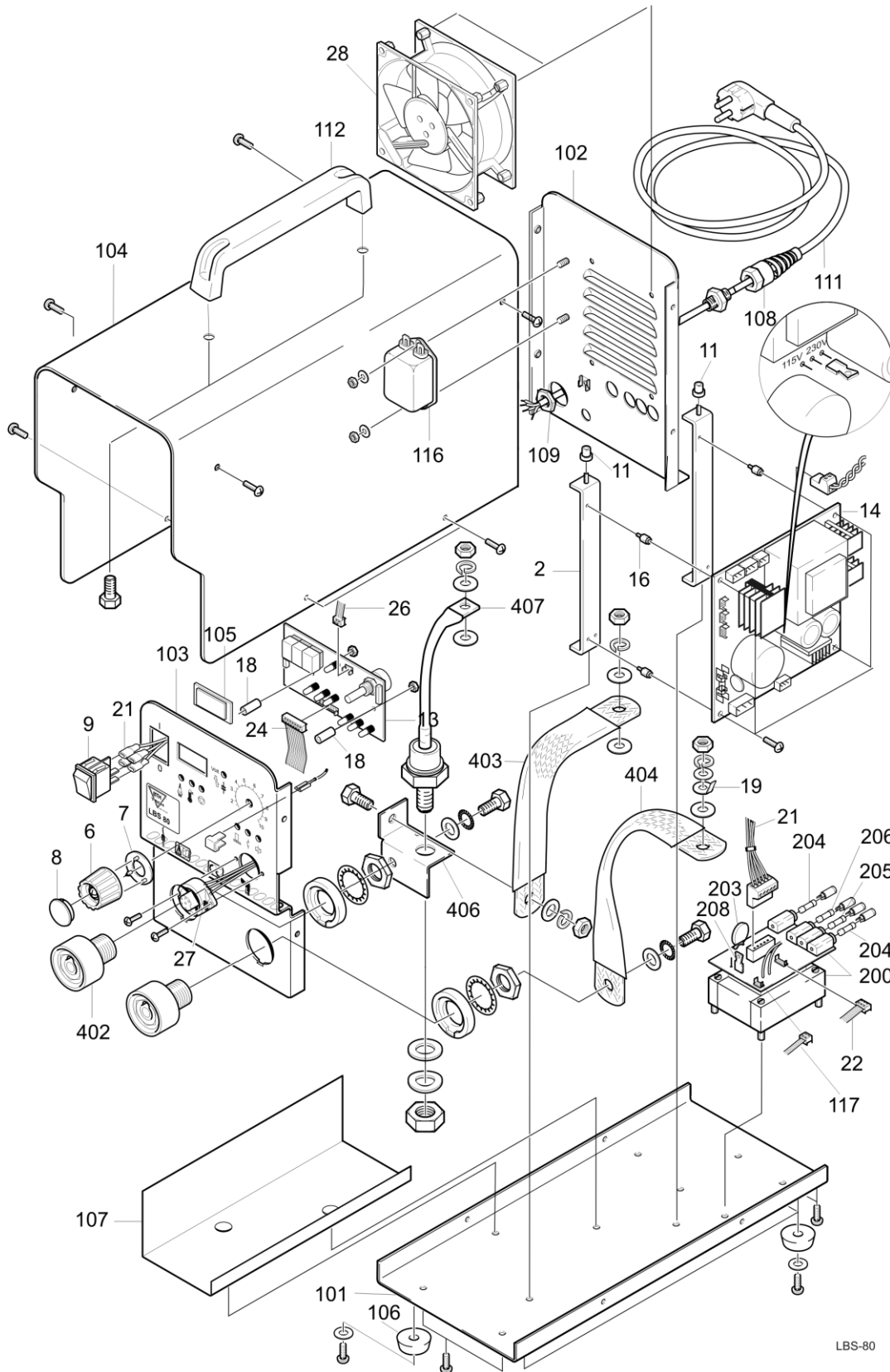

LBS-80

Explosion drawing stud welding unit: chassis, front panel etc.

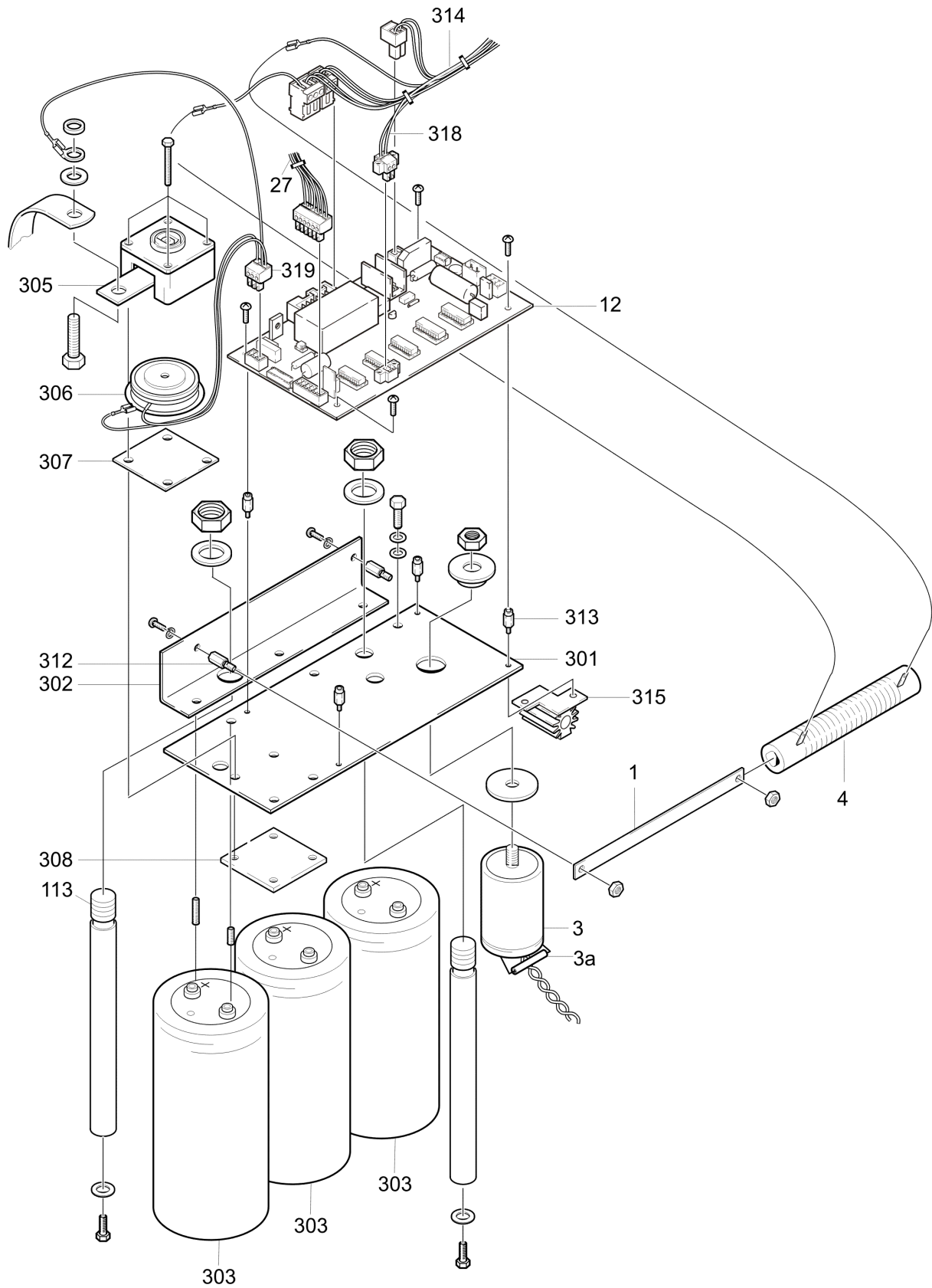

Explosion drawing stud welding unit: capacitors etc.

Position	Number	Part number	Description
1	1	B-80-40-1283	Resistor card housing LBS 066
2	2	B-80-40-1276	Card cage 066
3a	1	B-80-54-1012	Resistor 3K3 2W
3	1	B-80-52-1013	Capacitor E 4700U/ 100V
4	1	B-80-54-1010	Resistor 3R 70W
6	1	B-80-10-1115	Turning knob 28mm
7	1	B-80-10-1117	Arrow 28mm
8	1	B-80-10-1116	Lid 28mm
9	1	B-80-50-1027	Mains switch
11	2	B-80-40-1280	Insulation bush LBS 066
12	1	B-80-60-1166	Board LBS05/STD, compatible to 80-60-1066
13	1	B-80-60-1158	Board LED-FP
14	1	B-80-60-1164	Board, NTG-Thü-oNF
16	4	B-80-10-1173	Spacer stud 6K10IAM4ST
18	2	B-80-10-1035	Distance bush 7x15-3
19	1	B-80-10-1030	Flat connection 6,3/8
21	1	B-80-72-2040	Cable loop LBS 066 / mains
22	1	B-80-72-1073	Flat conductor L6/220
24	1	B-80-72-1045	Flat conductor L14/255
26	1	B-80-72-1069	Flat conductor L4/160
27	1	B-80-75-1012	Control cable module BE7/S6
28	1	B-80-50-1015	Ventilator K (nur LBS 80)
101	1	B-80-40-2060	Floor plate RAL 7016
102	1	B-80-40-2061	Back board RAL 7016
103	1	B-80-40-2064	Front plate RAL 7016
104	1	B-80-40-2067	Lid RAL 3020
105	1	B-80-40-1058	LED-Filter
106	4	B-80-10-1020	Housing foot 25/12
107	1	B-80-40-1277	Carboard insert LBS 066
108	1	B-80-10-1038	Cable connection PG9
109	1	B-80-10-1024	Screw nut PG9
111	1	B-80-50-1016	Mains connection
112	1	B-80-10-1214	Handle
113	2	B-80-40-1273	Distance stud 10-188-M10
116	1	B-80-50-1326	Line filter 5A
117	1	B-80-72-1085	Flat conductor L4/280 (nur LBS 80)
200	1	B-80-35-1172	BG Control transformer LBS 44 / 75
200	1	B-80-35-1060	BG Control transformer LBS 80
203	1	B-80-50-1136	Varistor S14K250
204	2	B-80-50-1031	Micro-fuse 4AF
205	1	B-80-50-1030	Micro-fuse 1AM
206	1	B-80-50-1062	Micro-fuse 0,25AF
208	1	B-80-10-1165	Connecting bridge
301	1	B-80-40-1275	Busbar - LBS 066
302	1	B-80-40-1274	Busbar + LBS 066
303	2/3	B-80-52-1012	Capacitor E 22.000/200 (bei Gerätekapazität 44000/66000 µF)
303	3	B-80-52-1062	Capacitor E 30.000/200

Position	Number	Part number	Description
			(bei Gerätekapazität 90000 µF)
305	1	B-80-10-1017	Straining cap 46x46/L
306	1	B-80-51-1011	Thyristor SKT
307	1	B-80-40-1041	Copper clad aluminium
308	1	B-80-40-1044	Clamping sheet 50x50
312	2	B-80-10-1047	Distance bolt 6K15IAM4ST
313	4	B-80-10-1177	Distance bolt 6K18IAM4ST
314	1	B-80-75-1023	Cable set LBS 066/KB 01
315	1	B-80-75-1024-1	Resistor with cable
318	1	B-80-75-1024	Cable set LBS 066/LE 01
319	1	B-80-50-1118	Socket cable Kabel 3/3,81
402	2	B-80-50-1022	Weld socket BE50
403	1	B-80-40-1394	CU fabric tape 195mm
404	1	B-80-40-1285	CU fabric tape 230mm
406	1	B-80-40-1272	Diode bracket LBS 066
407	1	B-80-51-1012	Diode SKR240/04

Spare parts list stud welding units

7.2 Spare parts contact stud welding gun PKM-1B

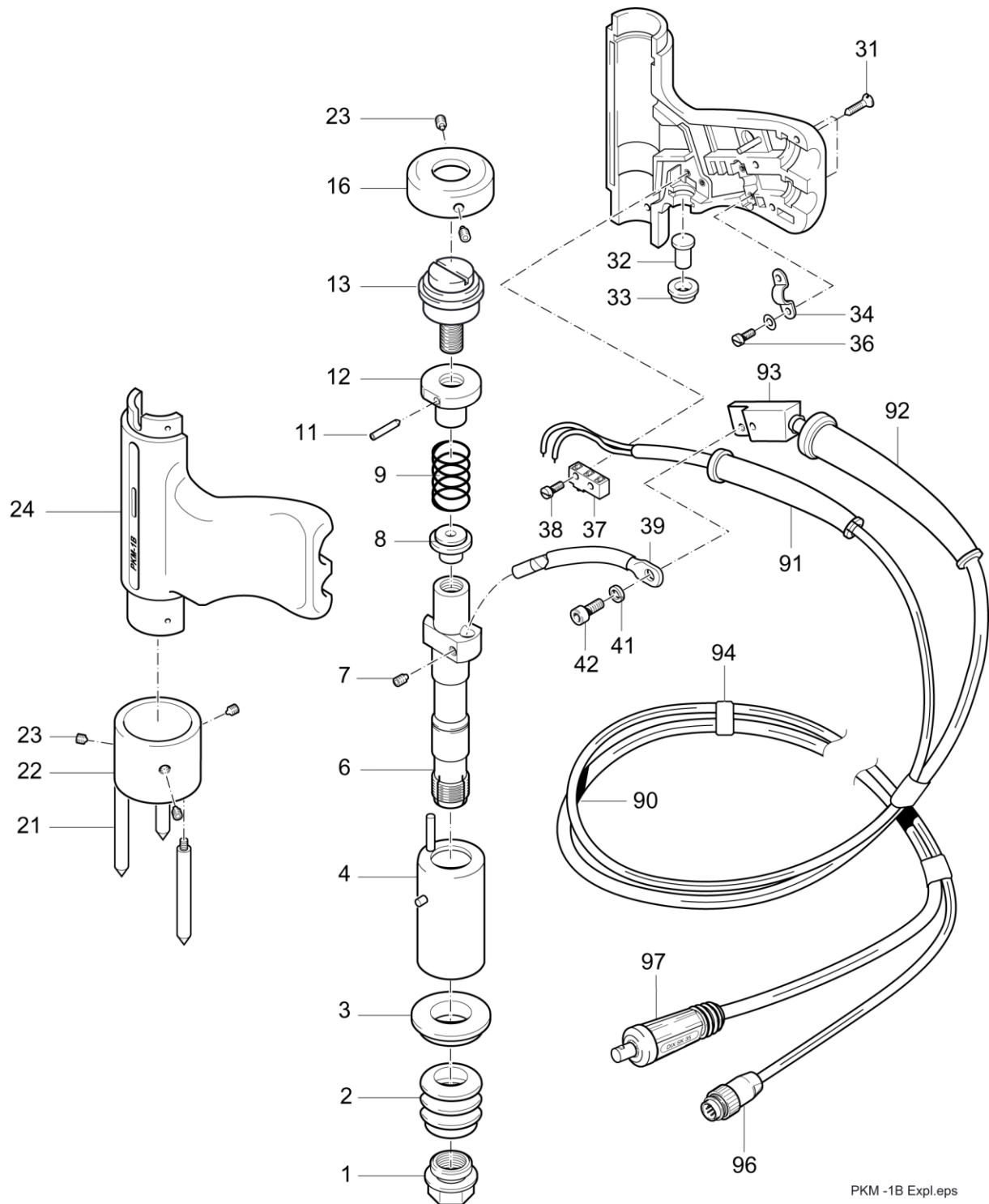

PKM-1B Expl.eps

Explosion drawing contact stud welding gun PKM-1B

Position	Number	Part number	Description
1	1	B-80-40-1014	Cap nut PHM1/4, PKM1
2	1	B-80-40-1097	Bellow PHM1/3/4, PKM1/2, PIM
3	1	B-80-40-1023	Insulation ring
4	1	B-80-40-1020	Guide bush
6	1	B-80-40-1011	Plunger PHM1 PKM1
7	1	B-80-15-1011	Grub screw M5x8, DIN 913
8	1	B-80-40-1027	Spring cap
9	1	B-80-40-1031	Pressure spring d=2; Da=20,7; Lo=35mm
11	1	B-80-15-1022	Grub screw M3x12, DIN 913
12	1	B-80-40-1015	Adjusting nut
13	1	B-80-40-1603	Adjusting screw
16	1	B-80-40-1028	End cap S
21	3	B-80-40-1012	Foot
22	1	B-80-40-1013	Foot ring 40/32
23	5	B-80-15-1010	Threaded pin M5x4, DIN 916
24	1	B-80-40-1602	Moulded recess neutral, PKM, PHM
31	3	B-80-15-1013	Raised countersunk-head tapping screw B 3,5x16, DIN 7983
32	1	B-80-40-1016	Pusher
33	1	B-80-40-1017	Bush
34	1	B-80-10-1015	Cable clip 4,5mm
36	2	B-80-15-1061	Screw M2,5x8; DIN 84
37	1	B-80-50-1013	Microswitch
38	2	B-80-15-1015	Screw M2x10; DIN 84
39	1	B-80-72-1012	Connecting cable 10/64
41	1	B-80-15-1016	Spring lock washer A4; DIN 127
42	1	B-80-15-1012	Screw M4x8; DIN 912
90	1	B-80-72-1039	Connecting lead 6,5M25Q35SK7SK
91	1	B-80-10-1011	Anti-kink sleeve ST
92	1	B-80-10-1013	Anti-kink sleeve 25qmm
93	1	B-80-35-1134	Contact block SL25 Set PKM/PHM
94	1	B-80-10-1012	Cable binder
96	1	B-80-50-1010	Cable plug 7GL
97	1	B-80-50-1080	Cable plug SK35
100	1	B-80-42-0025	Label PKM-1B

Spare parts list contact stud welding gun PKM-1B

7.3 Spare parts gap stud welding gun PHM-1A

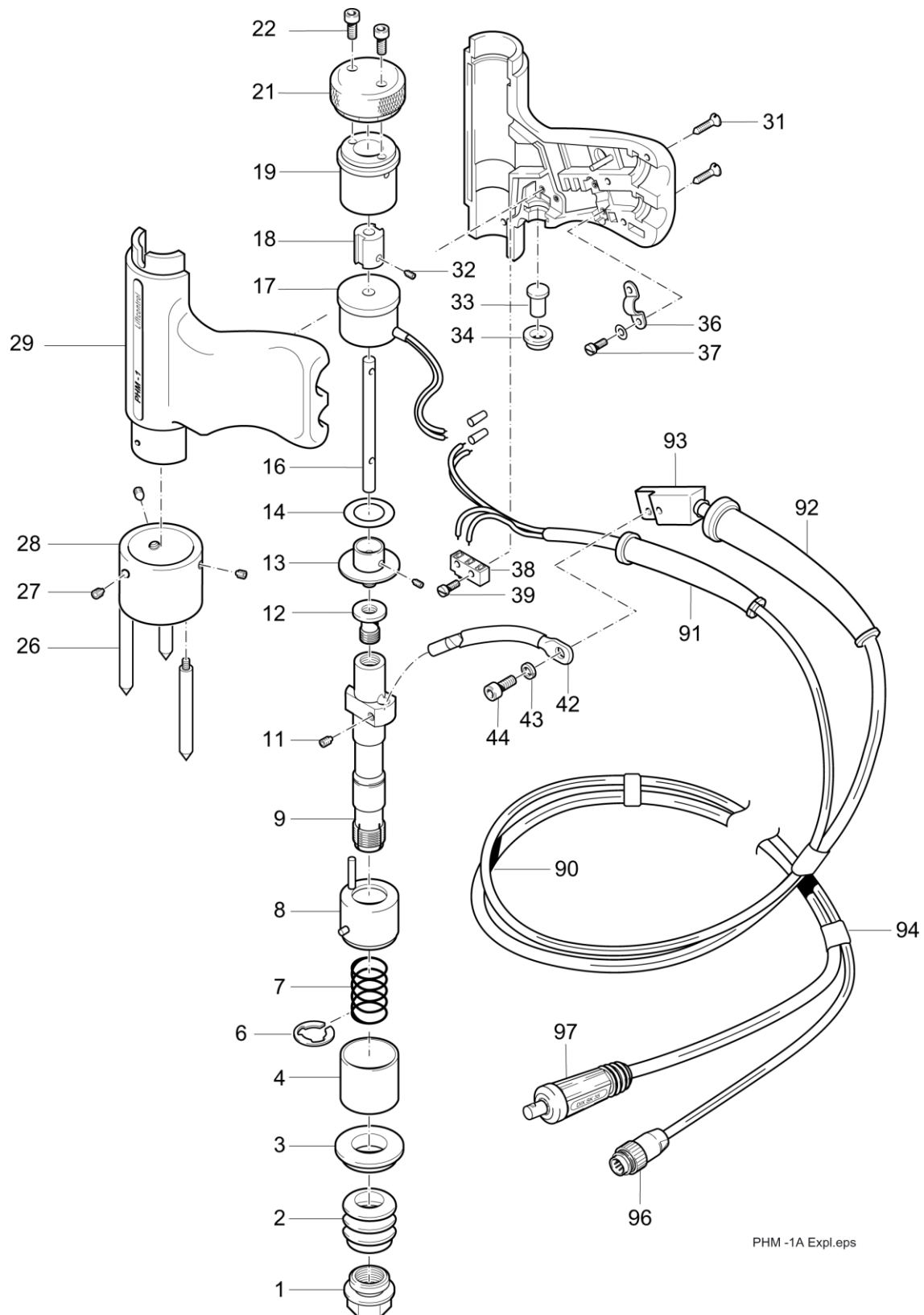

PHM -1A Expl.eps

Explosion drawing gap stud welding gun PHM-1A

Position	Number	Part number	Description
1	1	B-80-40-1014	Cap nut PHM1/4, PKM1
2	1	B-80-40-1097	Bellow PHM1/3/4, PKM1/2, PIM
3	1	B-80-40-1023	Insulation ring
4	1	B-80-40-1021	Guide
6	1	B-80-15-1023	Lock washer RA12
7	1	B-80-40-1038	Pressure spring d=1,5; Da=20,6; Lo=29,5mm
8	1	B-80-40-1022	Anti-twist protector
9	1	B-80-40-1011	Plunger PHM1, PKM1
11	1	B-80-15-1011	Grub screw
12	1	B-80-40-1033	Adaptor 17
13	1	B-80-40-1034	Armature PHM1
14	1	B-80-40-1035	MS-Washer
16	1	B-80-40-1036	Arbor
17	1	B-80-30-1010	Lift magnet PHM
18	1	B-80-40-1037	Slider
19	1	B-80-40-1025	Drawn arc adjustment
21	1	B-80-40-1075	End cap R
22	2	B-80-15-1030	Screw M3x6; DIN 912
26	3	B-80-40-1012	Foot
27	5	B-80-15-1010	Grub screw M5x4; DIN 916
28	1	B-80-40-1013	Foot ring 40/32
29	1	B-80-40-1602	Moulded recess neutral, PKM, PHM
33	1	B-80-40-1016	Pusher
34	1	B-80-40-1017	Bush
36	1	B-80-10-1015	Cable clip 4,5 mm
37	2	B-80-15-1061	Screw M2,5x8; DIN 84
38	1	B-80-50-1013	Microswitch
39	2	B-80-15-1015	Screw M2x10; DIN 84
42	1	B-80-72-1012	Connecting cable 10/64
43	1	B-80-15-1016	Pressure ring A4; DIN 127
44	1	B-80-15-1012	Screw M4x8; DIN 912
90	1	B-80-72-1022	Connecting lead 3M25Q35SK7SK
91	1	B-80-10-1011	Anti-kink sleeve ST
92	1	B-80-10-1013	Anti-kink sleeve 25qmm
93	1	B-80-35-1134	Contact block SL25, Set PKM/PHM
94	1	B-80-10-1012	Cable binder
96	1	B-80-50-1010	Cable plug 7GL
97	1	B-80-50-1080	Cable plug SK35
100	1	B-80-42-0011	Label PHM-1A

Spare parts list gap stud welding gun PHM-1A

7.4 Spare parts special stud welding gun PIM-1B

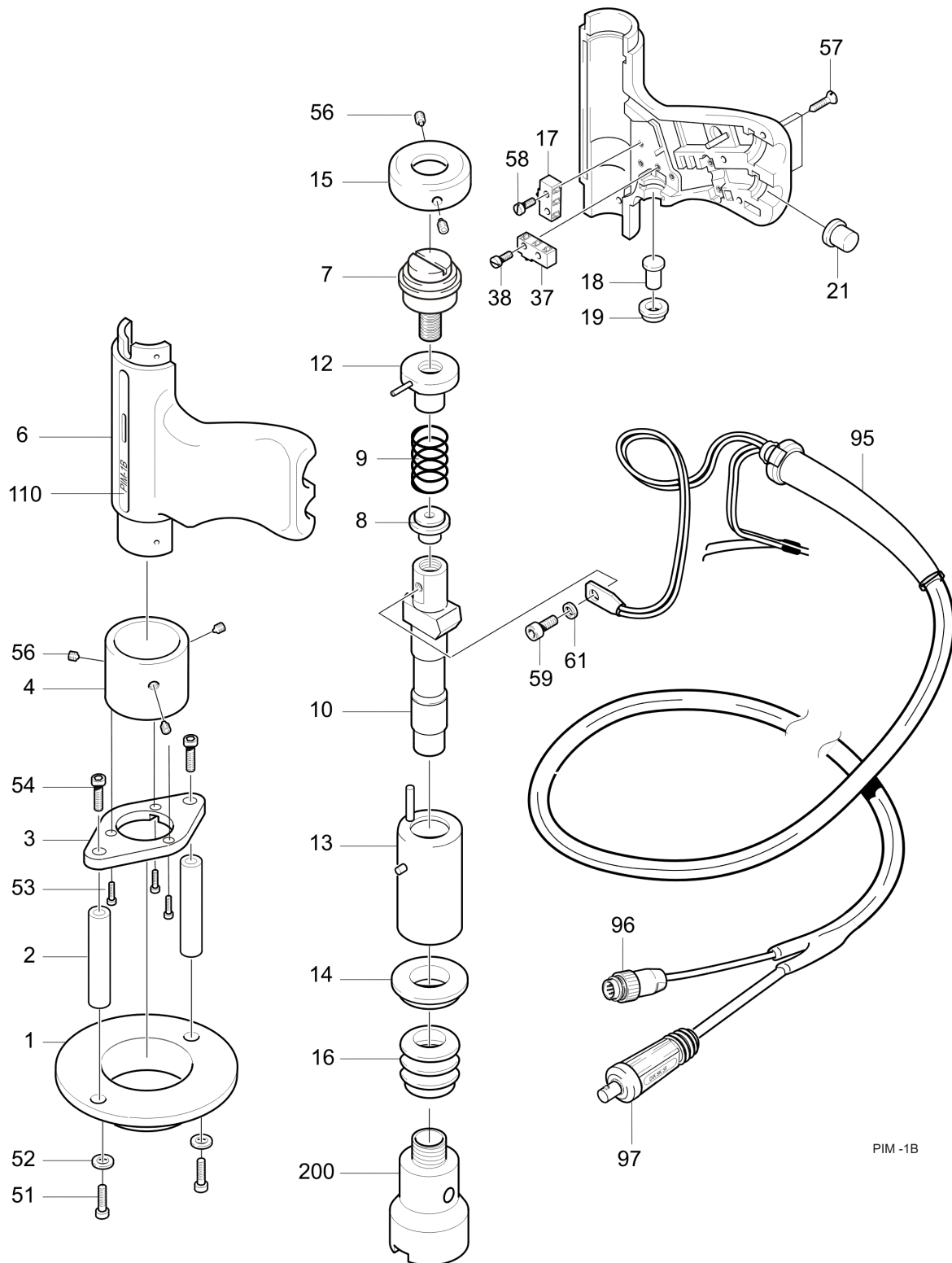

Explosion drawing special stud welding gun PIM-1B

Position	Number	Part number	Description
1	1	B-80-40-1215	Foot plate TS
2	2	B-80-40-1314	Spacer bolt
3	1	B-80-40-1216	Stand plate TS
4	1	B-80-40-1013	Foot ring 40/32
6	1	B-80-40-1613	Moulded recess PIM
7	1	B-80-40-1603	Adjusting screw
8	1	B-80-40-1027	Spring plate
9	1	B-80-40-1038	Pressure spring
10	1	B-80-40-1494	Stud
12	1	B-80-40-1015	Adjusting nut
13	1	B-80-40-1020	Guide bush
14	1	B-80-40-1023	Insulation ring
15	1	B-80-40-1028	End cap S
16	1	B-80-40-1097	Bellow
17/ 37	2	B-80-50-1013	Microswitch
18	1	B-80-40-1016	Pusher
19	1	B-80-40-1017	Bush
21	1	B-80-40-1249	Blank plug
38/ 58	4	B-80-15-1015	Screw M2x10
51	2	B-80-15-1064	Screw M5x16
52	2	B-80-15-1048	Washer DIN 125
53	3	B-80-15-1072	Screw M4x6
54	2	B-80-15-1073	Screw M5x12
56	5	B-80-15-1010	Grub screw M5x4
57	3	B-80-15-1013	Raised-countersunk head tapping screw
59	1	B-80-15-1012	Screw M4x8
61	1	B-80-15-1016	Lock washer A4
95	1	B-80-72-1055	Connecting lead
96	1	B-80-50-1010	Cable plug 7GL
97	1	B-80-50-1080	Cable plug SK25
110	1	B-80-42-0024	Label PIM –1B
200	1	82-50-0301	Magnetic chuck(optional)

Spare parts list special stud welding gun PIM-1B

The contents of this publication were checked for correspondence with the hardware it describes. Nevertheless, discrepancies cannot be ruled out, for which reason complete correspondence cannot be guaranteed. However, the contents of this publication are checked regularly and any corrections needed are incorporated in following editions. Please send us your recommendations for improvement.

No part of this document may be duplicated, passed on or communicated to others or used otherwise unless expressly permitted. Violations will be prosecuted to the full extent of the law. All rights reserved, especially in the event of a patent being granted or a utility patent being registered.

BTH Tech GmbH

Ohmstraße 3
D-85221 Dachau

Telephone: +49 (0)8131 51590

Fax: +49 (0)8131 515911

info@bth-tech.de

www.bth-tech.de